

Chapter 4

Results

- The Creation of *Tu Giac* Housing Conservation Prototype related to the Deterioration/Destruction of 6 Outstanding *Tu Giac* House Characteristics

Based on the conditions of decay and destruction of the *Tu Giac* houses mentioned in Chapter 3, this chapter provides the possible Conservation Methods and Techniques (D) to maintain, repair, or replace the decayed parts or elements of *Tu Giac* houses. The application of conservation methods on the *Tu Giac* Housing Prototype has led to the *Tu Giac* Housing Conservation Prototype which offers the guidelines for the conservation and restoration of all *Tu Giac* houses in accordance with the related Charters and Laws of Conservation (C). The technical drawings together with the 3D-illustrations are used to present the Methods and Techniques of Conservation for *Tu Giac* houses.

4.1 The Load Bearing Walls

4.1.1 Charter & Principles (A₁-C):

The Venice Charter has focused on the respect to and the authenticity of the original building fabric. The notion *as historical evidence* in Article 3: “The intension in conserving and restoring monuments is to safeguard them no less as work of art than as historical evidence”¹ indicates that the retention of original building fabric is essential to fulfill “our duty to hand them (monuments) on in the full richness of their

¹ Venice Charter, Article 3.

authenticity.”² The original *Vo* bricks and sizes of the load bearing walls have to be retained as many as possible, as in Principle 1 of the *Ruong House Conservation*:

“The conservation has to keep the original materials, form, and sizes as many as possible.”³ And again, it is highlighted in the Law on Cultural Heritage of Vietnam:

“Preservation is the activity to prevent and minimize dangers of damage without changing inherent original elements.”⁴ It means that “deteriorated structures whenever possible should be repaired rather than replaced.”⁵

In cases of seriously damaged, the safeguarding of *Tu Giac* houses is highly noticed consistent with Venice Charter: “The moving of all or part of a monument cannot be allowed except where the safeguarding of that monument demands it.”⁶ In the conservation of load bearing walls, the extremely decayed walls should be consolidated. However, the consolidation with its elements “do not falsify the artistic or historic evidence”⁷ of the load bearing walls according to Venice Charter.

4.1.2 Conservation Methods (A₁-D): C1, C2, P1, P2 in the TGCP (*the set of conservation technical drawings*) later.

ลิขสิทธิ์มหาวิทยาลัยเชียงใหม่

Copyright© by Chiang Mai University

All rights reserved

² *Ibid.*, Preamble.

³ *Ruong House Conservation Principles*, Principle 1.

⁴ *Law on Cultural Heritage of Vietnam*, Article 4.

⁵ *ICOMOS Charter 2003*, Remedial Measures and Controls.

⁶ *Venice Charter*, Article 7.

⁷ *Venice Charter*, Article 12.

4.2 Two-storey Buildings

4.2.1 Charter & Principles (A₂-C):

The Venice Charter takes the authenticity into consideration as the aim of conservation. And from Article 3 as mentioned in 3.3.1.1, it confirms that only the original building fabric can ensure the authenticity. Additional parts are not allowed if they “detract from the interesting parts of the building, its traditional setting, the balance of its composition”.⁸ It indicates that additional parts harmful to the special scales in façade of the original two-storey fabric of *Tu Giac* houses must be removed for the respect to and the retaining “their original materials, form, and sizes as many as possible”.⁹

4.2.2 Conservation Methods (A₂-D): B in TGCP later.

4.3 The High-Pitch Timber Stair

4.3.1 Charter & Principles (A₃-C):

The original characteristics bearing the history of the stair and the house like the high slope, the narrow access, the big distance of two stair-steps must be maintained.

Decayed original parts whenever possible “should be repaired rather than replaced.”¹⁰

In the certain circumstances of serious decays, the conservation of the stair may “require the complete or partial dismantling and subsequent reassembly in order to

⁸ *Venice Charter*. Article 13.

⁹ *Ruong House Conservation Principles*. Principle 1.

¹⁰ *ICOMOS Charter 2003*. Remedial Measures and Controls.

allow for the repair of timber structures.”¹¹ In cases of replacement, new parts must be “made of the same species of wood with the same, or, if appropriate, with better, grading as in the members being replaced”.¹²

4.3.2 Conservation Methods (A₃-D): S1, T2 in the TGCP later.

4.4 The Timber Floor on the 2nd level

4.4.1 Charter & Principles (A₄-C):

The conservation ought to “prevent and minimize dangers of damage without changing inherent original elements”.¹³ The original parts of the floor such as the timber beams and planks and their connections should be retained as the historical evidences since “a monument is inseparable from the history to which it bears witness”.¹⁴ The conservation on them must “keep their original materials, form, and sizes as many as possible”¹⁵ consistent with the objective “the best therapy is preventive maintenance”.¹⁶

Similar to the timber stair, in cases of severe destruction, the conservation techniques may need the complete or partial dismantling and subsequent reassembly for the repair of the floor and, if replacement required, the new parts should be the

¹¹ *Principles for the Preservation of Historic Timber Structures*. Interventions.

¹² *Ibid.*, Repair and Replacement.

¹³ *Law on Cultural Heritage of Vietnam*. Article 4.

¹⁴ *Venice Charter*. Article 7.

¹⁵ *Ruong House Conservation Principle*. Principle 1.

¹⁶ *ICOMOS Charter 2003*. Remedial Measures and Controls.

same species of wood of the members being replaced so that it “does not falsify the artistic or historical evidence.”¹⁷

4.4.2 Conservation Methods (A₄-D): T1, T2, T3 in the TGCP later.

4.5 The Hip Roof

4.5.1 Charter & Principles (A₅-C)

The original fabric must be highly respected due to its bearing of historical evidence according to Venice Charter. It is required to “keep their original materials, forms, and sizes as many as possible”¹⁸ consistent with the point “the best therapy is preventive maintenance”.¹⁹ It is the way to prevent damage “without changing inherent original elements.”²⁰ Stitch

In case of the timber frame system of hip roof, the conservation may “require the complete or partial dismantling and subsequent reassembly in order to allow for the repair of timber structures.”²¹ With the seriously decayed parts, new parts are used for replacing and should “be made of the same species of wood as in the members being replaced.”²²

¹⁷ Venice Charter. Article 12.

¹⁸ Ruong House Conservation Principles. Principle 1.

¹⁹ ICOMOS Charter 2003. Remedial Measures and Controls.

²⁰ Law on Cultural Heritage of Vietnam. Article 4.

²¹ Principles for Preservation of Historic Timber Structures. Interventions.

²² Ibid., Repair and Replacement.

Decayed *Liet* tiles “whenever possible should be repaired rather than replaced.”²³

4.5.2 Conservation Methods (A₅-D): R1, R2, R3 in the TGCP later.

4.6 The Entrance Doors using filled-in Horizontal Wooden Panels & The Shutter Windows

4.6.1 Charter & Principles (A₆-C):

The original building parts like doors and windows, according to Venice Charter, should be kept due to its bearing the witness of history. The conservation of them may “require the complete or partial dismantling and subsequent reassembly in order to allow for the repair of timber structures”.²⁴

In case of replacing serious decayed members, new members should be made of the same species of wood being replaced.²⁵

In case of replacing the missing parts, new parts must “integrate harmoniously with the whole” and “be distinguishable from the original so that the restoration does not falsify the artistic or historic evidence”.²⁶

4.6.2 Conservation Methods (A₈-D): D, W in the TGCP later.

4.7 The *Tu Giac* Housing Conservation Prototype (TGCP):

(See the set of technical drawings on the next pages)

²³ ICOMOS Charter 2003. Remedial Measures and Controls.

²⁴ *Principles for Preservation of Historic Timber Structures*. Interventions.

²⁵ *Principles for Preservation of Historic Timber Structures*. Repair and Replacement.

²⁶ *Venice Charter*. Article 12.

-THE *TU GIAC* HOUSING CONSERVATION PROTOTYPE-

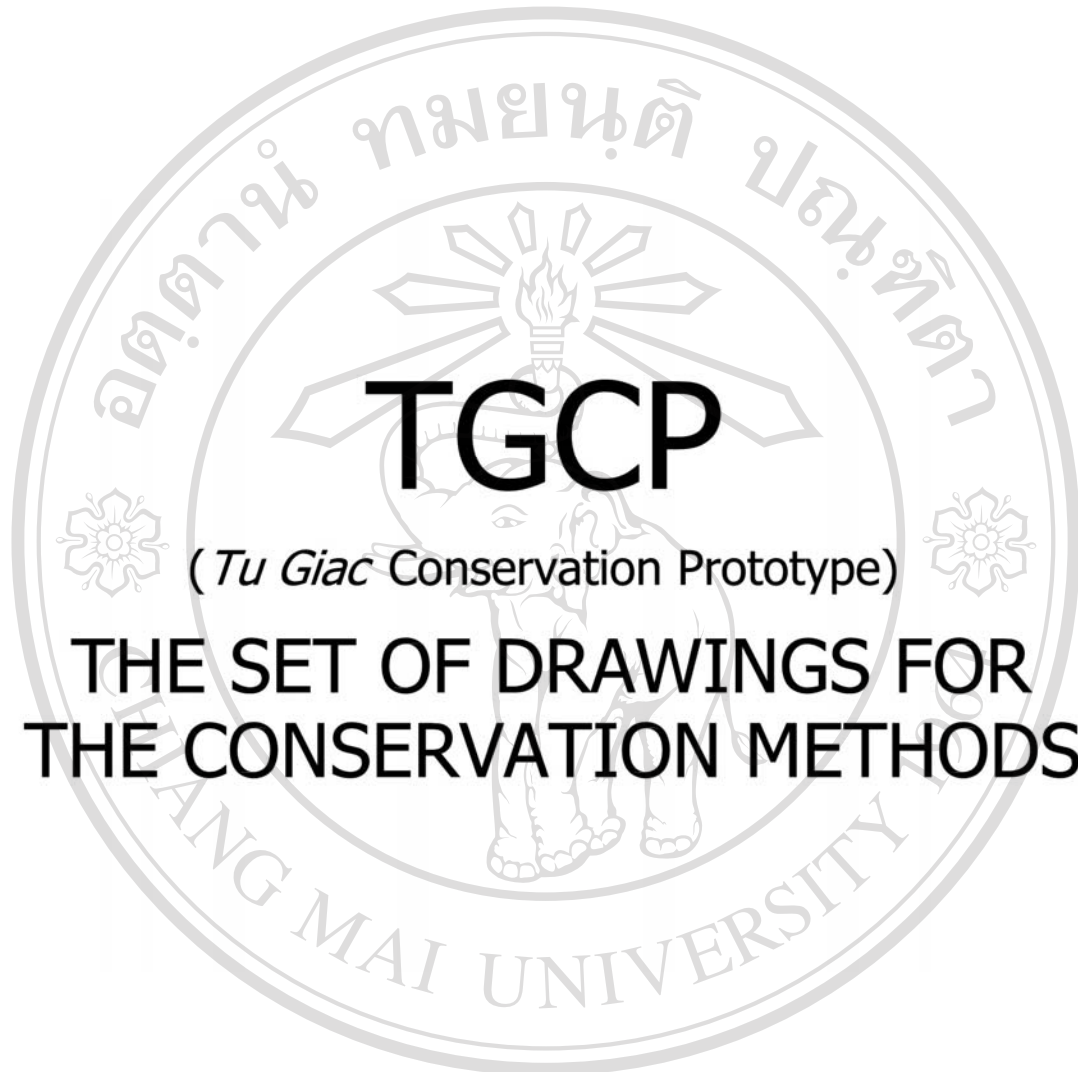

TGCP

(*Tu Giac* Conservation Prototype)

**THE SET OF DRAWINGS FOR
THE CONSERVATION METHODS**

ลิขสิทธิ์มหาวิทยาลัยเชียงใหม่

Copyright© by Chiang Mai University

All rights reserved

2008







THE *TU GIAC* HOUSING CONSERVATION PROTOTYPE

Fig.4.1 A Table showing 15 conservation techniques for Tu Giac houses (Drawing P-09 through P-22)

Decays & Destructions	Methods	Description	Steps for Conservation	Drawing Number
1. Cracks	C1	- Deep cracks damaging the brick-block	step 1- 7	P-09
	C2	- Surface cracks without damaging the brick-block	step 1- 5	P-10
2. Plasters	P1	- Decayed plaster due to climatic impacts	step 1- 7	P-11
	P2	- Decayed plaster due to annual floods	step 1- 6	P-12
3. Timbers	T1	- Cracks > 5mm width on timber beams and bars	step 1- 4	P-13
	T2	- Cracks < 5mm width on timber beams and bars	step 1- 2	P-14
	T3	- Decayed endpoints of the timber planks of the floor	step 1- 4	P-17
4. Roofing	R1	- Cracks on the masonry roof ridges	step 1- 4	P-15
	R2	- Decayed Liet tiles of the hip roof	step 1- 2	P-18
	R3	- Decayed timber elements of the hip roof	step 1- 4	P-19
5. Stairs	S1	- Decayed endpoints of the high-pitch timber stair	step 1- 5	P-16
6. Doors & Windows	D	- Entrance door using filled-in horizontal wooden panels	step 1- 2	P-20
	W	- The slat-wooden-shutter window	step 1- 2	P-21
7. Facade Restoration	F1	- Encouraging additions being removed from facade		P-22
	F2	- Facade restoration after additions being removed		

THE *TU GIAC* HOUSING CONSERVATION PROTOTYPE

Fig.4.2 The 15 conservation techniques in relation to the 6 Architectural Characteristics (A1 through A6):

6 ARCHITECTURAL CHARACTERISTICS	CONSERVATION METHODS
 THE LOAD BEARING WALLS	C1, C2, P1, P2
 THE TWO-STOREY BUILDINGS	F1, F2
  THE HIGH-PITCH TIMBER STAIR	S1, T2
 THE TIMBER FLOOR ON THE 2ND LEVEL	T1, T2, T3
 THE HIP ROOF	R1, R2, R3
 THE ENTRANCE DOOR USING FILLED-IN HORIZONTAL WOODEN PANELS & THE SHUTTER WINDOWS	D, W

Notes:

1. Six Architectural Characteristics of the *Tu Giac* House (A1-A6) are referred in the architectural plans of *Tu Giac* House in the next pages.
2. The total of 15 conservation techniques in the *Tu Giac* Housing Conservation Prototype have been explained step by step and illustrated by the technical drawings afterward.

ARCHITECTURAL PLANS OF THE *TU GIAC* HOUSE

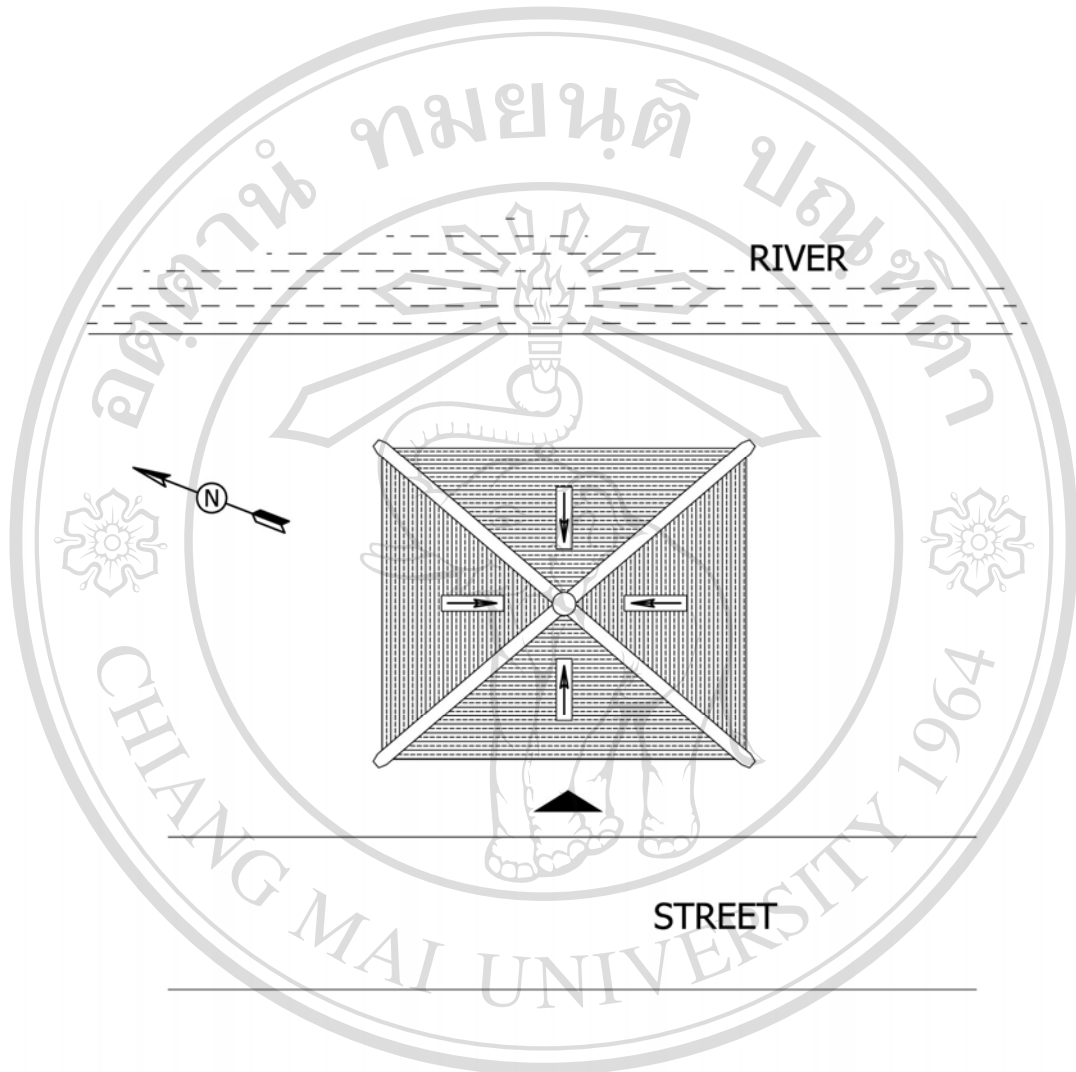

ลิขสิทธิ์มหาวิทยาลัยเชียงใหม่
Copyright© by Chiang Mai University
All rights reserved

1 ROOF PLAN
Scale: 1:100

Project name and address THE TU GIAC HOUSING CONSERVATION PROTOTYPE HUE CITY, VIETNAM		Sheet No.
Name and address TRAN TUAN ANH FACULTY OF ARCHITECTURE, CHIANG MAI UNIVERSITY	Scale 1: 100	P-01
	Date Aug - 2008	

ARCHITECTURAL PLANS OF THE *TU GIAC* HOUSE

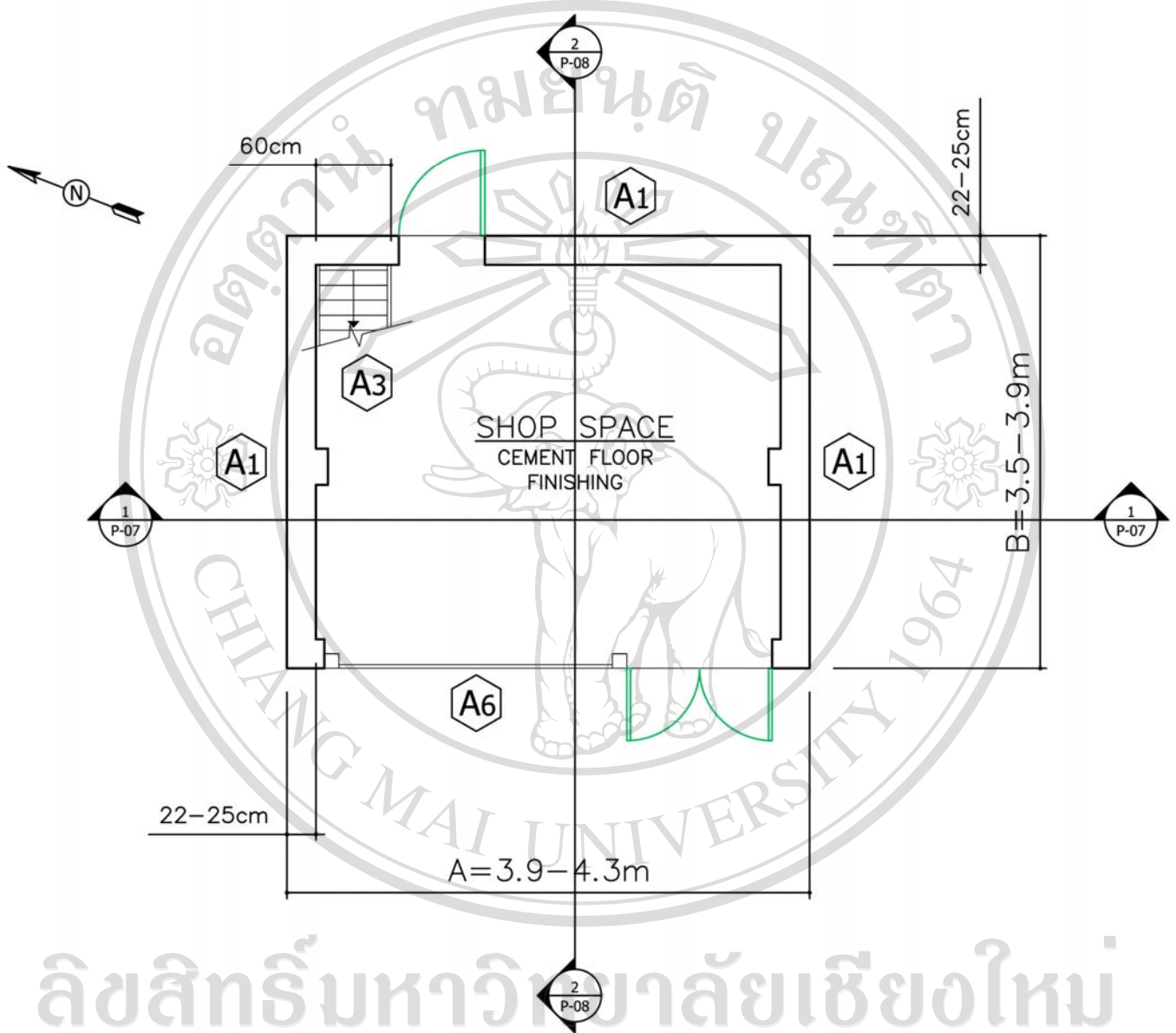

ลิขสิทธิ์มหาวิทยาลัยเชียงใหม่
 Copyright © by Chiang Mai University
 All rights reserved

2 GROUND FLOOR PLAN
 Scale: 1:50

Project name and address THE TU GIAC HOUSING CONSERVATION PROTOTYPE HUE CITY, VIETNAM		Sheet No.
Name and address TRAN TUAN ANH FACULTY OF ARCHITECTURE, CHIANG MAI UNIVERSITY	Scale 1: 50	P-02
	Date Aug - 2008	

ARCHITECTURAL PLANS OF THE *TU GIAC* HOUSE

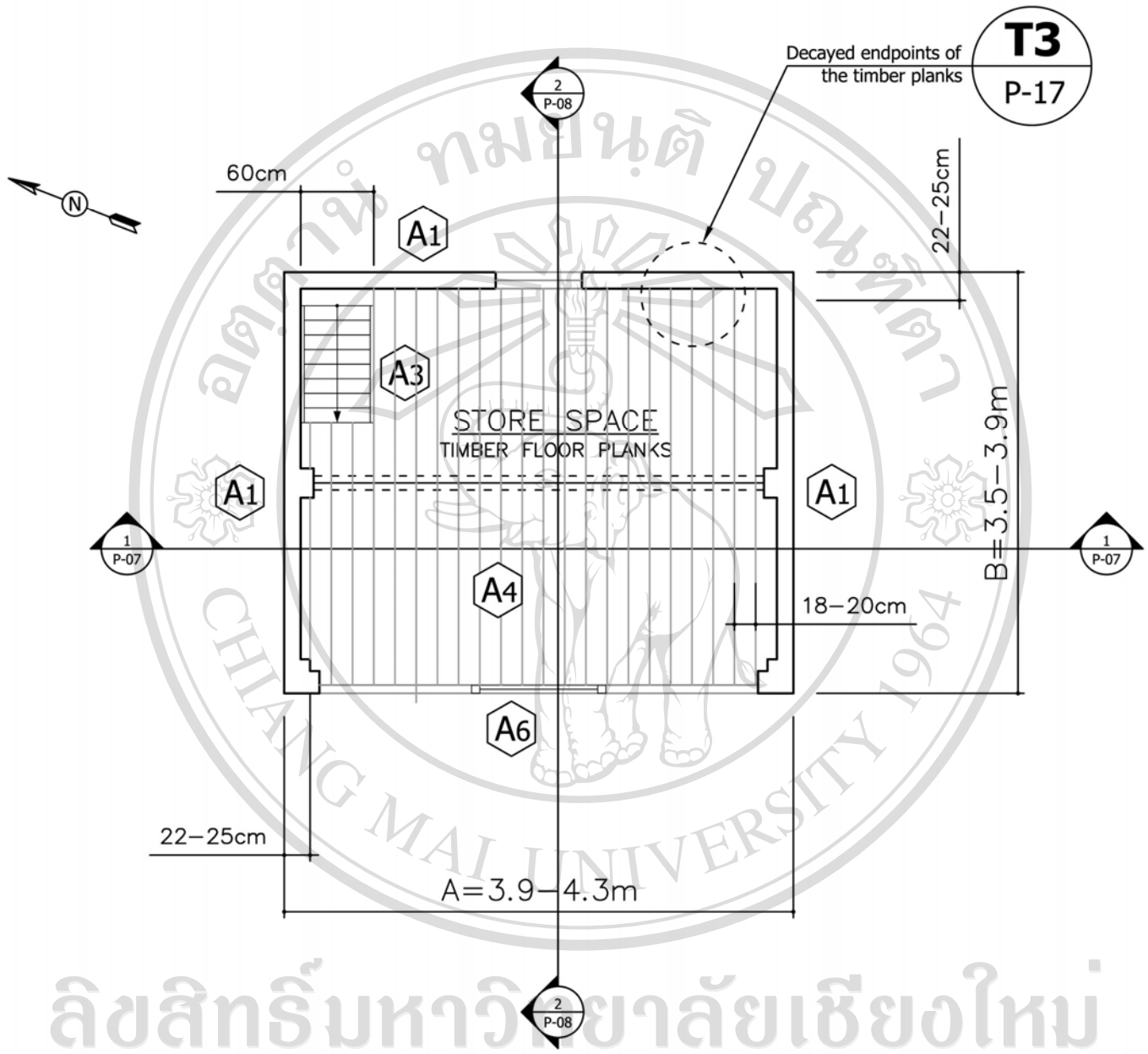

3 **2ND FLOOR PLAN**
Scale: 1:50

ลิขสิทธิ์มหาวิทยาลัยเชียงใหม่
Copyright © by Chiang Mai University
All rights reserved

Project name and address THE TU GIAC HOUSING CONSERVATION PROTOTYPE HUE CITY, VIETNAM		Sheet No.
Name and address TRAN TUAN ANH FACULTY OF ARCHITECTURE, CHIANG MAI UNIVERSITY	Scale 1: 50	P-03
	Date Aug - 2008	

ARCHITECTURAL PLANS OF THE *TU GIAC* HOUSE

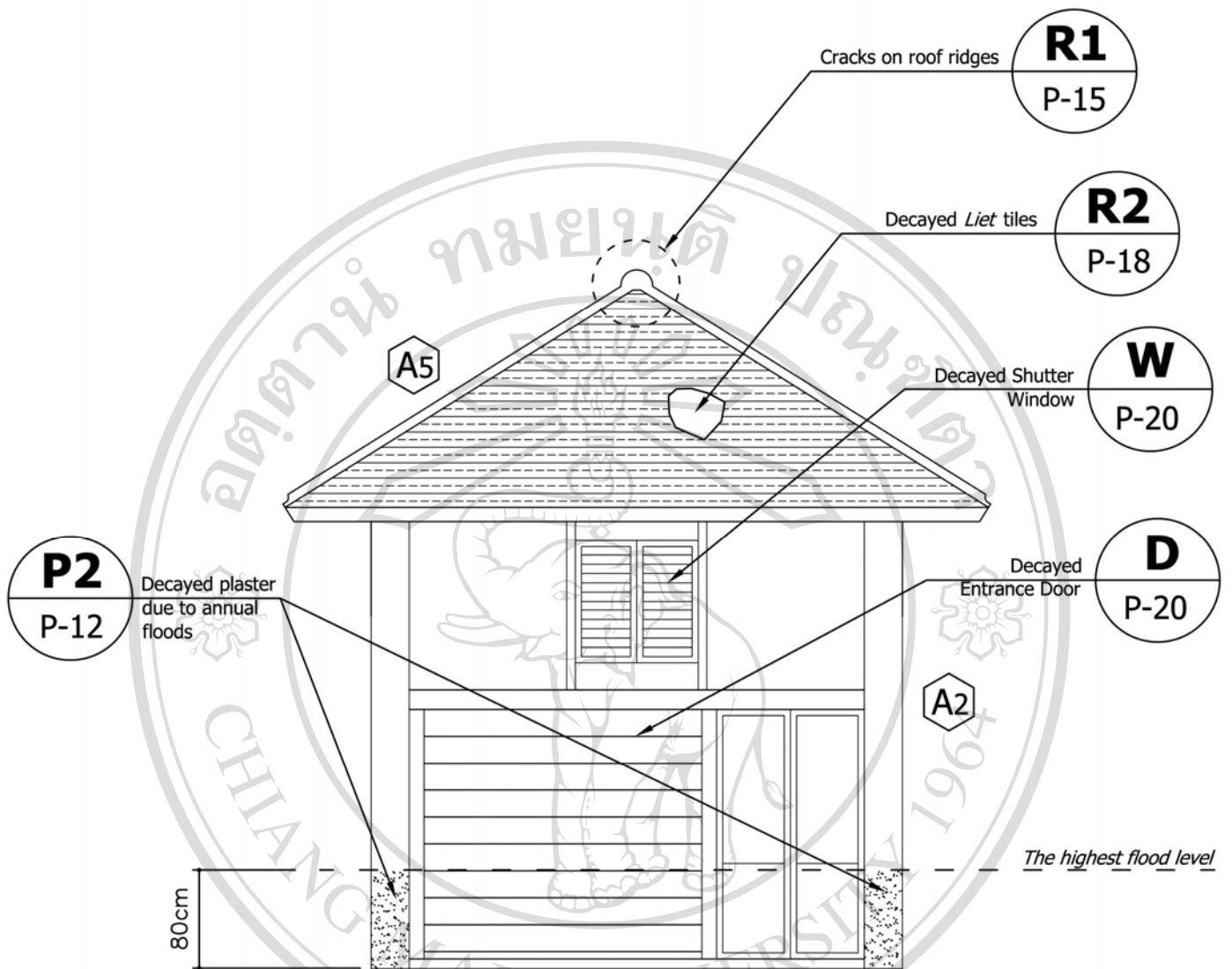

4 FRONT ELEVATION
Scale: 1:50

ลิขสิทธิ์มหาวิทยาลัยเชียงใหม่
Copyright© by Chiang Mai University
All rights reserved

Project name and address THE TU GIAC HOUSING CONSERVATION PROTOTYPE HUE CITY, VIETNAM		Sheet No.
Name and address TRAN TUAN ANH FACULTY OF ARCHITECTURE, CHIANG MAI UNIVERSITY	Scale 1: 50	P-04
	Date Aug - 2008	

ARCHITECTURAL PLANS OF THE *TU GIAC* HOUSE

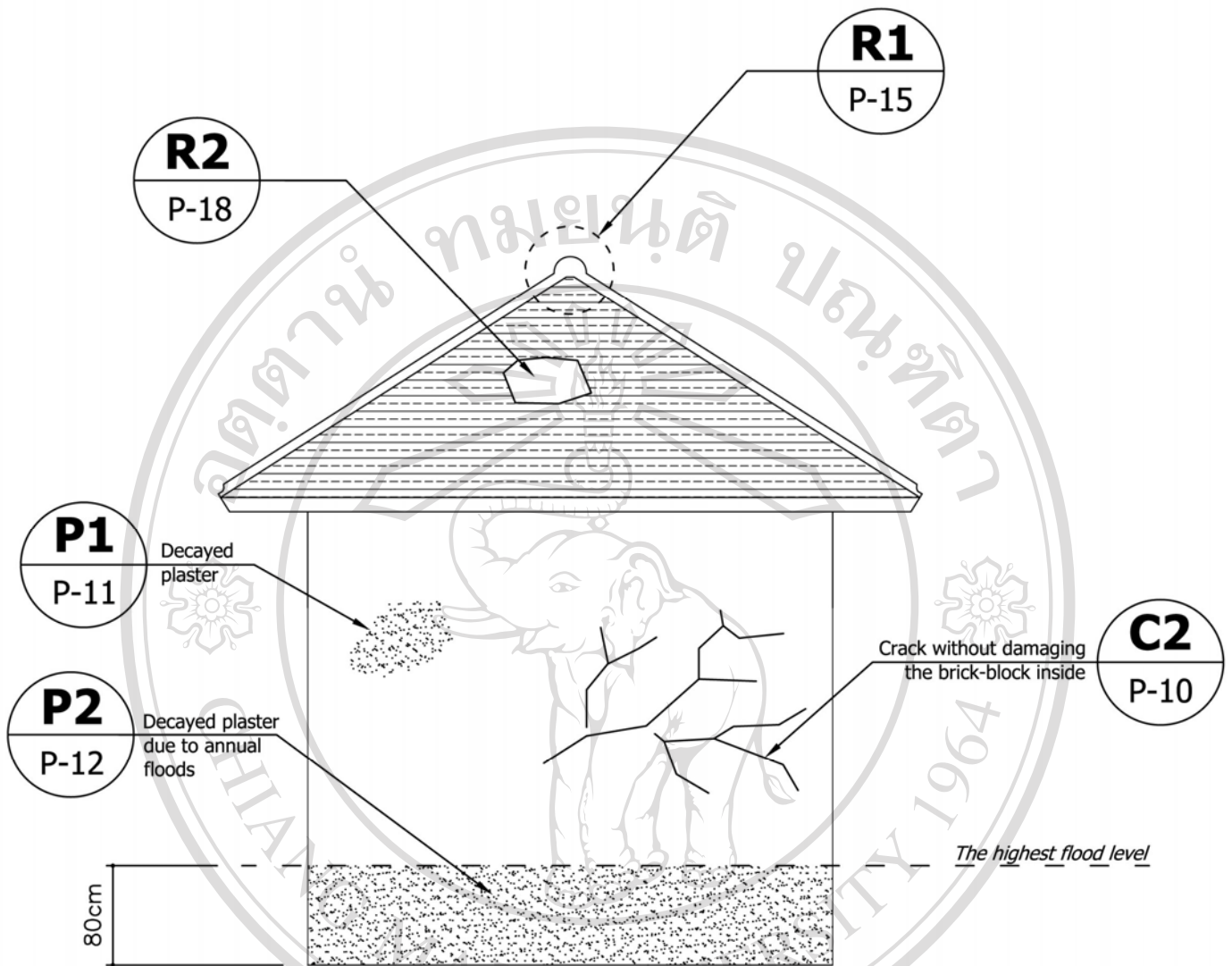

5

SIDE ELEVATION

Scale: 1:50

ลิขสิทธิ์มหาวิทยาลัยเชียงใหม่
 Copyright© by Chiang Mai University
 All rights reserved

Project name and address THE TU GIAC HOUSING CONSERVATION PROTOTYPE HUE CITY, VIETNAM		Sheet No.
Name and address TRAN TUAN ANH FACULTY OF ARCHITECTURE, CHIANG MAI UNIVERSITY	Scale 1: 50	P-05
	Date Aug - 2008	

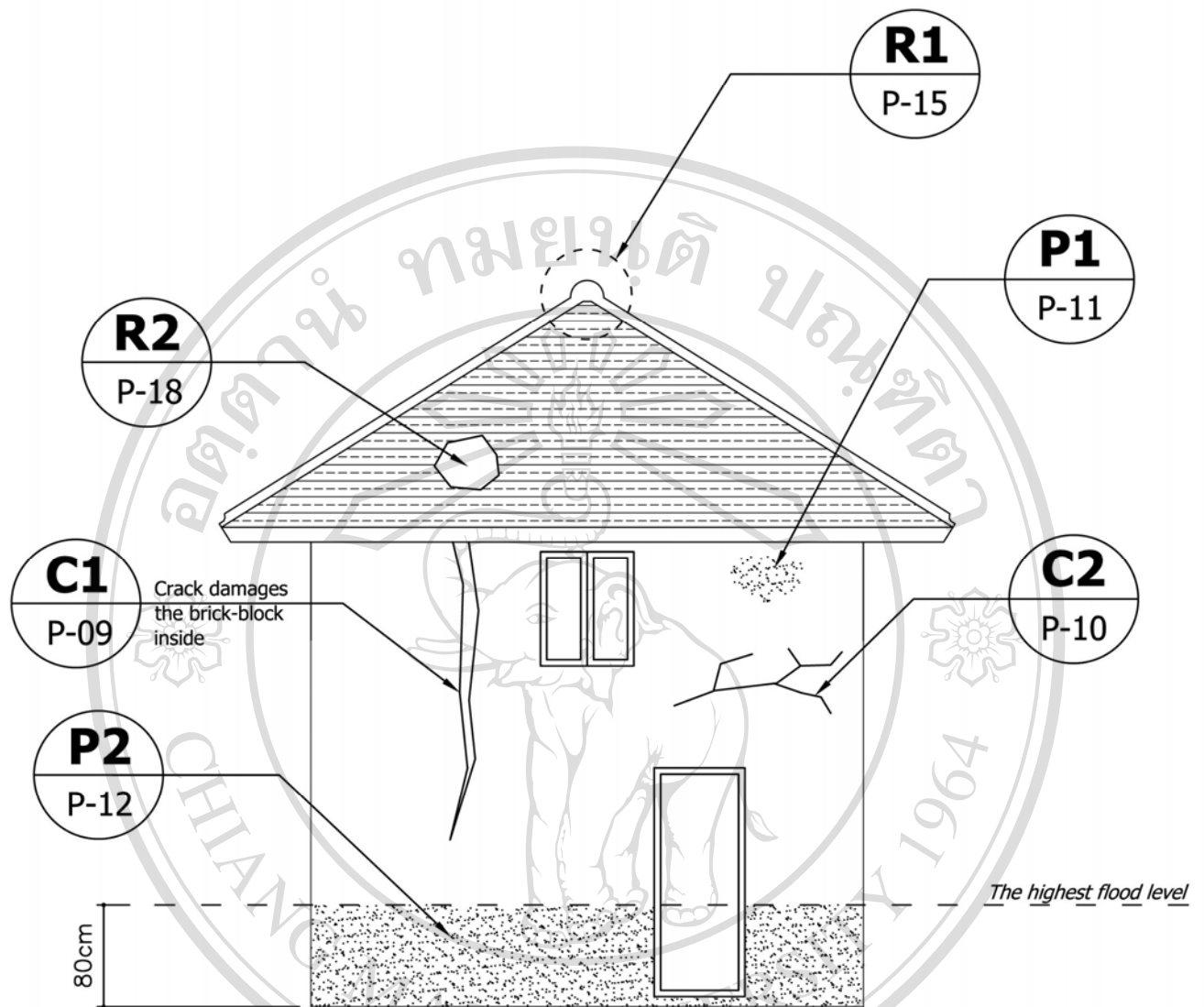

6 REAR ELEVATION

Scale: 1:50

ลิขสิทธิ์มหาวิทยาลัยเชียงใหม่
 Copyright© by Chiang Mai University
 All rights reserved

Project name and address THE TU GIAC HOUSING CONSERVATION PROTOTYPE HUE CITY, VIETNAM		Sheet No.
Name and address TRAN TUAN ANH FACULTY OF ARCHITECTURE, CHIANG MAI UNIVERSITY	Scale 1: 50	P-06
	Date Aug - 2008	

ARCHITECTURAL PLANS OF THE *TU GIAC* HOUSE

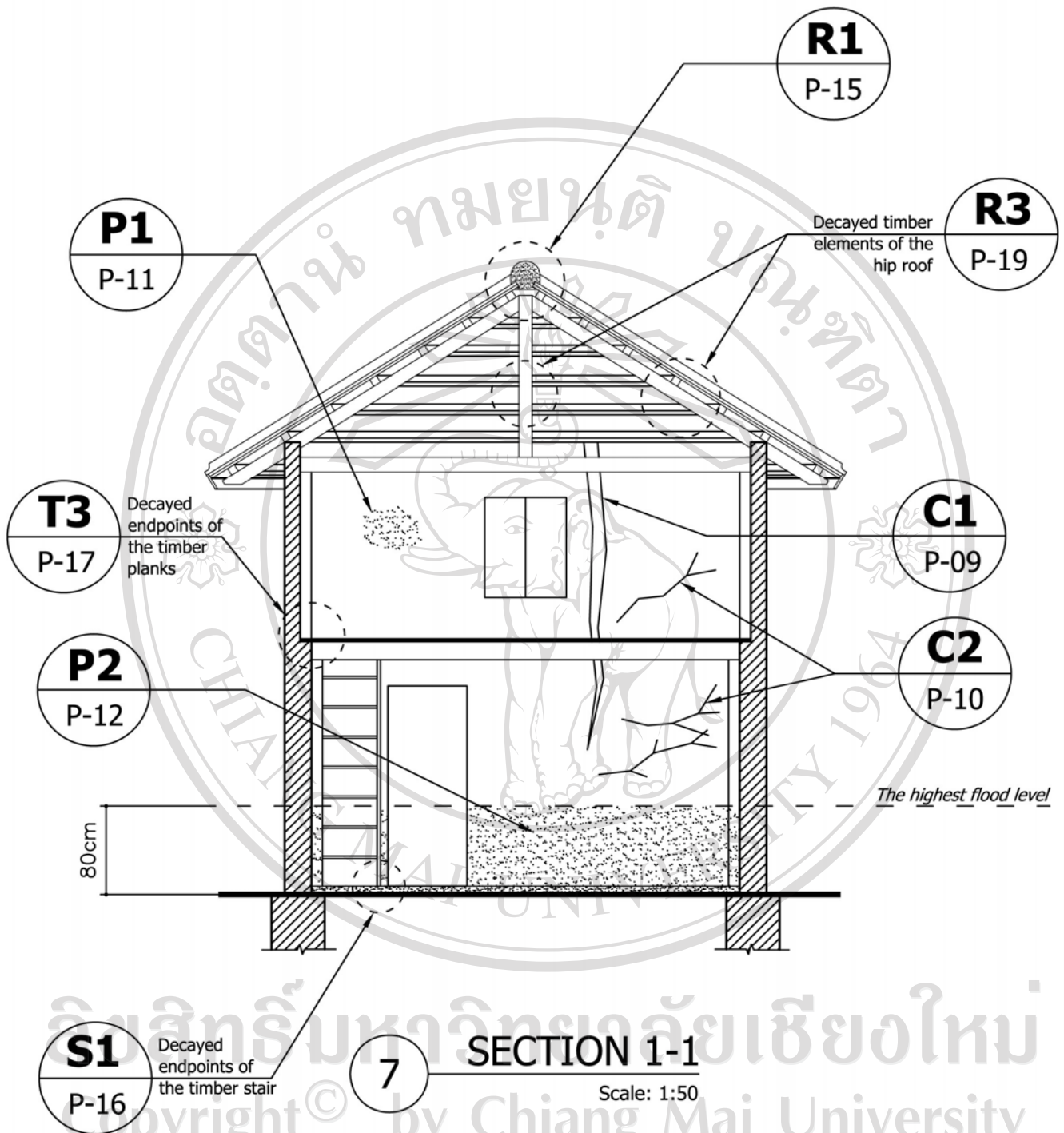

ลิขสิทธิ์มหาวิทยาลัยเชียงใหม่
Copyright © by Chiang Mai University
All rights reserved

Project name and address THE TU GIAC HOUSING CONSERVATION PROTOTYPE HUE CITY, VIETNAM		Sheet No.
Name and address TRAN TUAN ANH FACULTY OF ARCHITECTURE, CHIANG MAI UNIVERSITY	Scale 1: 50	P-07
	Date Aug - 2008	

ARCHITECTURAL PLANS OF THE *TU GIAC* HOUSE

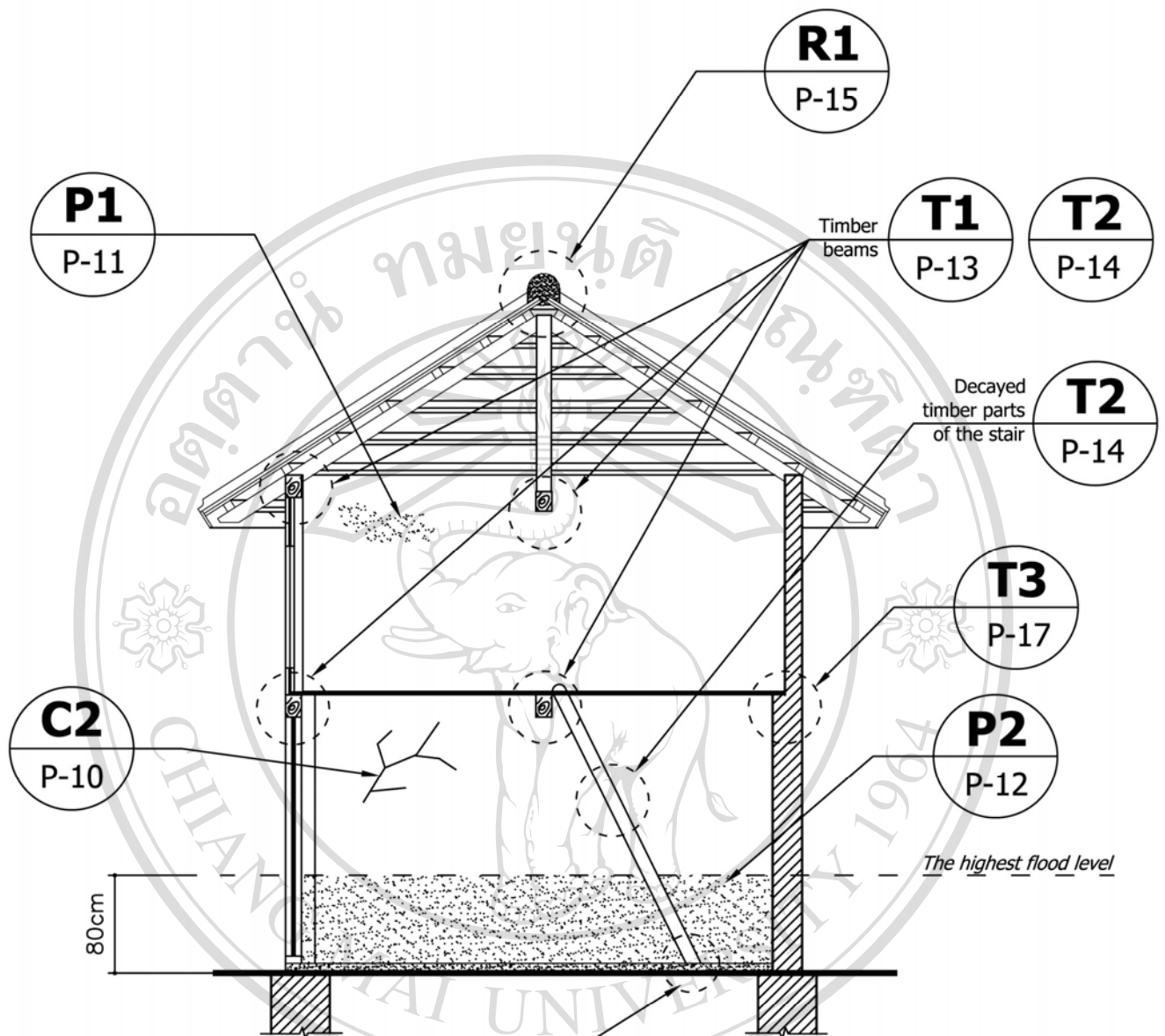

S1

P-16

8

SECTION 2-2

Scale: 1:50

ลิขสิทธิ์มหาวิทยาลัยเชียงใหม่
 Copyright © by Chiang Mai University
 All rights reserved

Project name and address THE TU GIAC HOUSING CONSERVATION PROTOTYPE HUE CITY, VIETNAM		Sheet No.
Name and address TRAN TUAN ANH FACULTY OF ARCHITECTURE, CHIANG MAI UNIVERSITY	Scale 1: 50	P-08
	Date Aug - 2008	

METHODS FOR THE DEEP CRACKS DAMAGING THE BRICK-BLOCK

Notes:

The methods applied here is the *stitching of the cracks* by the metallic elements. It is the use of steel rods to sew the openings of the crack, especially with the large cracks deepening into the brick-block.

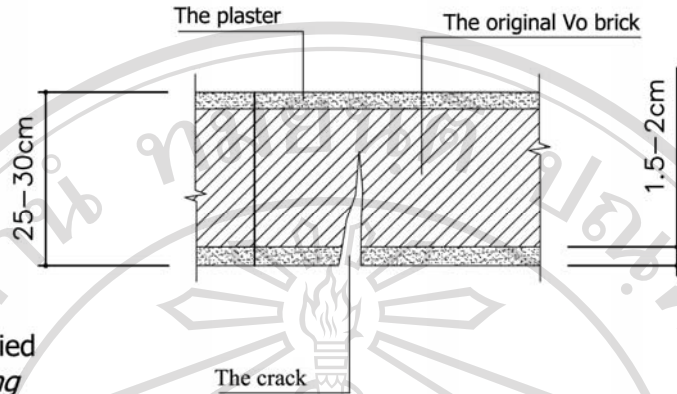

STEP 1
Scale: 1:10

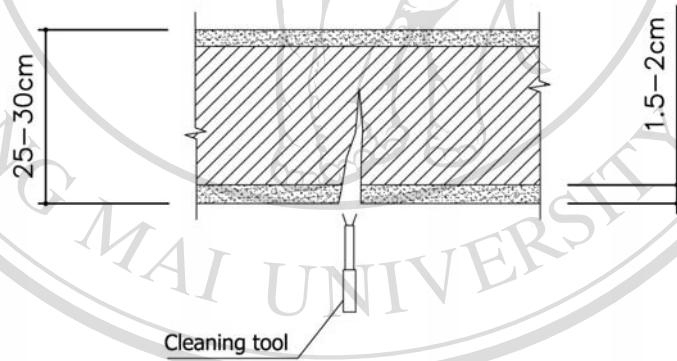

STEP 2
Scale: 1:10

+ Brick-block of the walls by Vo bricks, the solid fired clay-bricks, were plastered by the lime-cement mortar and covered by the colored-whitewash as the finishing.

+ The crack is generally caused by the instability of the foundation such as the subsidence. This techniques is helpful once it is combined with the ways of consolidating foundation which is not mentioned in the scope of the study.

+ Deep cracks which are usually long and have the wide-openings should be cleaned carefully by the air-compressor before applying the repair techniques.

ลิขสิทธิ์มหาวิทยาลัยเชียงใหม่
Copyright © by Chiang Mai University
All rights reserved

- Step 1:**
+ Identify the cracks which destroy the brick-block of the wall
- Step 2:**
+ Clean the crack and the wall surface surrounding

Project name and address THE TU GIAC HOUSING CONSERVATION PROTOTYPE HUE CITY, VIETNAM		Sheet No.
Name and address TRAN TUAN ANH FACULTY OF ARCHITECTURE, CHIANG MAI UNIVERSITY	Scale 1: 10	P-09.1
	Date Aug - 2008	

METHODS FOR THE DEEP CRACKS DAMAGING THE BRICK-BLOCK

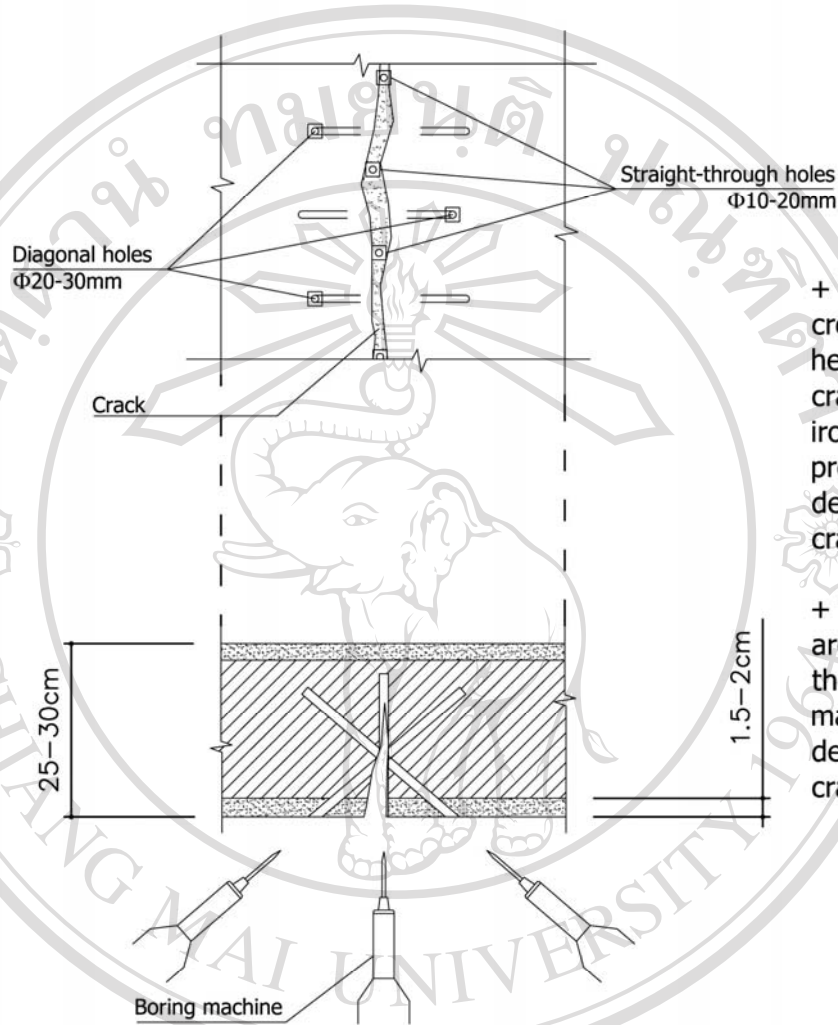

+ The diagonal holes crossing the crack help to stitch the crack by putting the iron bars inside and prevent the development of the crack's opening.

+ The straight holes are used to pump the adhesive material to the deepest parts of the crack easily.

C1

STEP 3

Scale: 1:10

Step 3:

+ Use boring-machine with the auger Φ20-30mm to bore the diagonal holes along and on both sides of the crack so that they cross the crack. The depth of them is 20-25cm and the distance among them is 30-50cm.

+ Use boring machine with the auger Φ10-20mm to bore the straight-through holes along and in the crack. Its depth is 2-5cm and the distance among them is 20-30cm.

Project name and address THE TU GIAC HOUSING CONSERVATION PROTOTYPE HUE CITY, VIETNAM		Sheet No.
Name and address TRAN TUAN ANH FACULTY OF ARCHITECTURE, CHIANG MAI UNIVERSITY	Scale 1: 10	P-09.2
	Date Aug - 2008	

METHODS FOR THE DEEP CRACKS DAMAGING THE BRICK-BLOCK

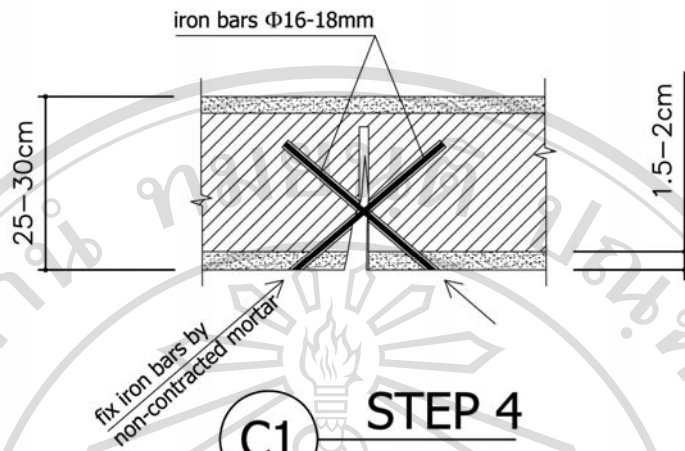

+ The non-contracted mortar, the mortar without contracting after drying, can strengthen the connecting of the iron bars with the brick-block.

Scale: 1:10

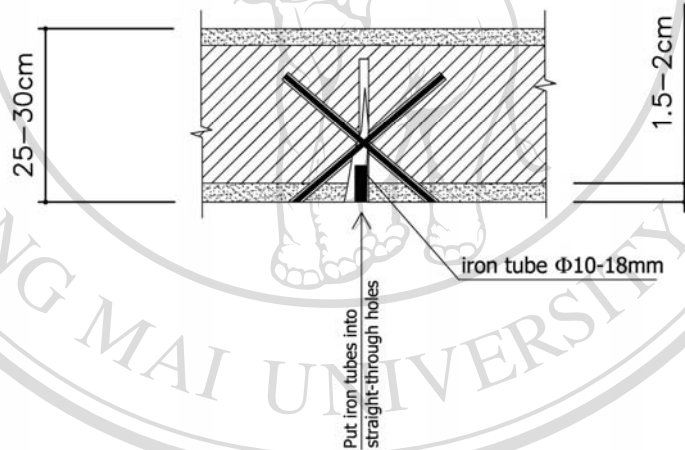

+ The iron tubes are fixed in the straight holes to lead the adhesive material go deeply into the crack when pumping.

Scale: 1:10

Step 4:

- + Cleaning the boring holes and fixing the rust-resistant iron bars $\Phi 16-18\text{mm}$ inside the diagonal holes by non-contracted mortar
- + Cutting the outside part of iron bars and finishing surfaces of diagonal holes

Step 5:

- + Putting the iron tube $\Phi 10-18\text{mm}$ inside the straight-through holes

Project name and address THE TU GIAC HOUSING CONSERVATION PROTOTYPE HUE CITY, VIETNAM		Sheet No.
Name and address TRAN TUAN ANH FACULTY OF ARCHITECTURE, CHIANG MAI UNIVERSITY	Scale 1: 10	P-09.3
	Date Aug - 2008	

METHODS FOR THE DEEP CRACKS DAMAGING THE BRICK-BLOCK

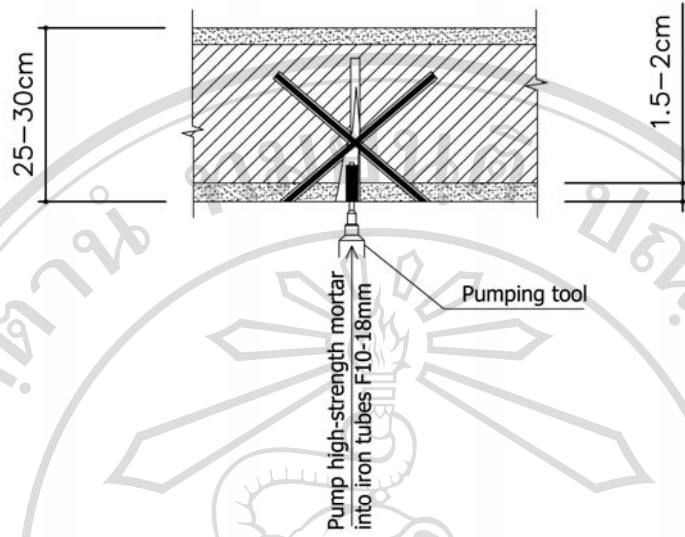

+ The adhesive material of high-strength mortar is filled in the crack through the iron tubes fixed on the straight holes.

C1 STEP 6

Scale: 1:10

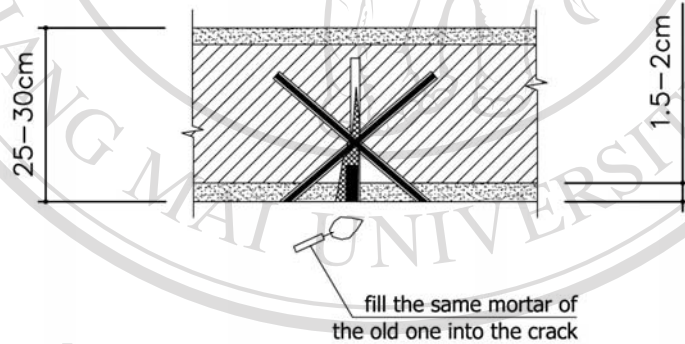

+ To return the same wall surface with the same physical properties of material, the same mortar of existing wall, the lime-cement mortar, is used to plaster on the holes.

+ The selected colored-whitewash is finally coated on the whole surface of the wall including the old and new plaster.

C1 STEP 7

Scale: 1:10

Step 6:

- + Using the air-compressor to clean the crack again
- + Pumping the high-strength mortar into the straight-through holes

Step 7:

- + Cutting the outside parts of iron tubes
- + Filling the crack by the same mortar of old one (here is lime-cement mortar) and finishing the wall surfaces

ลิขสิทธิ์มหาวิทยาลัยเชียงใหม่
 Copyright © by Chiang Mai University
 All rights reserved

Project name and address THE TU GIAC HOUSING CONSERVATION PROTOTYPE HUE CITY, VIETNAM		Sheet No.
Name and address TRAN TUAN ANH FACULTY OF ARCHITECTURE, CHIANG MAI UNIVERSITY	Scale 1: 10	P-09.4
	Date Aug - 2008	

METHODS FOR THE SURFACE CRACKS WITHOUT DAMAGING THE BRICK-BLOCK

Notes:

With the smaller cracks without destroying the brick-block inside as in this case, the *method of grout injection* is applied for filling the cracks.

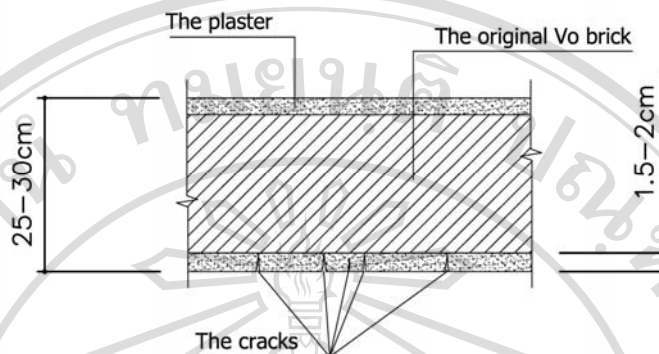

STEP 1
C2 Scale: 1:10

+ The cracks are caused by thermal expansion and contraction of the plaster, especially the uneven thermal expansion and contraction of the plaster and brick-block.

+ The cracks are happened in the plaster only. However, its opening can help water and fungi contact and destroy the brick-block through time.

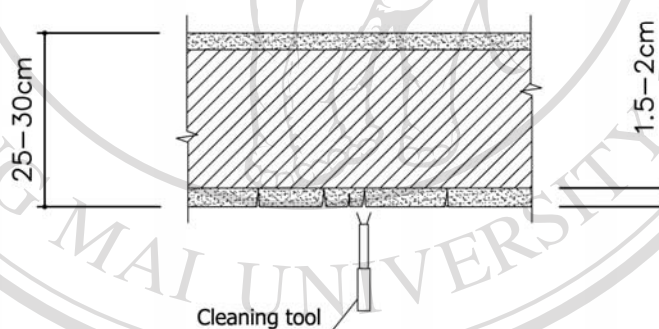

STEP 2
C2 Scale: 1:10

+ The careful cleaning done by the air-compressor must dispose of all dusts or dirt scattered into the cracks.

ลิขสิทธิ์มหาวิทยาลัยเชียงใหม่
Copyright © by Chiang Mai University
All rights reserved

Step 1:

+ Identify the crack without destroying the brick inside (occurred on plaster only)

Step 2:

+ Cleaning the cracks and wall surface surrounding them

Project name and address THE TU GIAC HOUSING CONSERVATION PROTOTYPE HUE CITY, VIETNAM		Sheet No.
Name and address TRAN TUAN ANH FACULTY OF ARCHITECTURE, CHIANG MAI UNIVERSITY	Scale 1: 10	P-10.1
	Date Aug - 2008	

METHODS FOR THE SURFACE CRACKS WITHOUT DAMAGING THE BRICK-BLOCK

+ Because the cracks are so small that the pumping tool cannot be placed in, the boring of bigger holes on the cracks is needed to fill the adhesive material (Epoxy resin or Sikadure Glue 752) by pumping into those cracks.

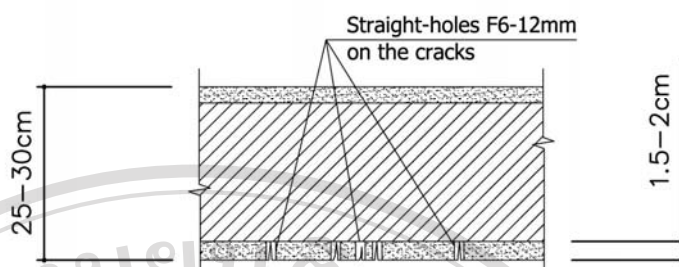

STEP 3
Scale: 1:10

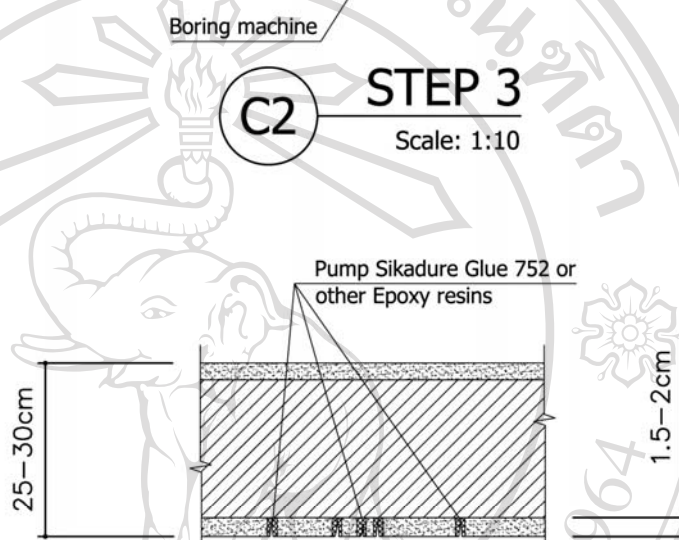

STEP 4
Scale: 1:10

Step 3:

+ Use boring machine with the auger $\Phi 6-12\text{mm}$ to bore the holes on the cracks. Their depth is limited in the thickness of plaster

Step 4:

+ Cleaning the boring holes
+ Pumping the Sikadure Glue 752 or other Epoxy resins into the boring holes

Step 5:

+ Finishing the wall surface by plastering the same mortar (here is the lime-cement mortar)

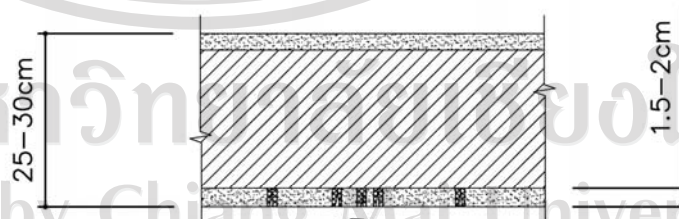

STEP 5
Scale: 1:10

Project name and address THE TU GIAC HOUSING CONSERVATION PROTOTYPE HUE CITY, VIETNAM		Sheet No.
Name and address TRAN TUAN ANH FACULTY OF ARCHITECTURE, CHIANG MAI UNIVERSITY	Scale 1: 10	P-10.2
	Date Aug - 2008	

METHODS FOR THE DECAYED PLASTER DUE TO CLIMATIC IMPACTS

Notes:

+ The conservation purpose is to coat a good external layer for protection of the brick-block, the most important material in the load bearing wall.

+ The *brick-coating method* is applied for treating decayed plaster. It is in fact the use of one thin water-proof layer to cover the bricks inside before plastering the new mortar.

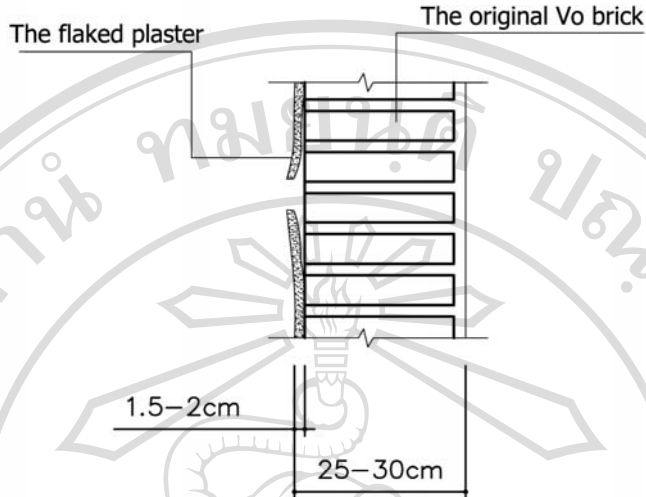

+ The decayed plaster is lacked of or has no cohesion in material. The mortar tends to turn powder and be flaked or fallen down through time.

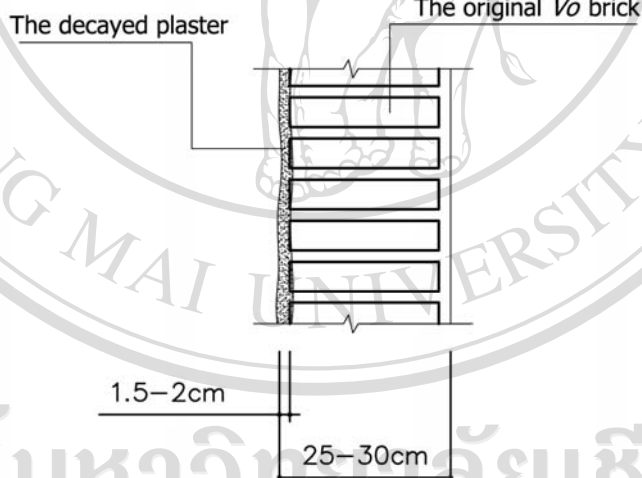

+ The water or moisture can be absorbed through the decayed plaster easily and cause damage of the brick-block.

ลิขสิทธิ์มหาวิทยาลัยเชียงใหม่

Copyright© by Chiang Mai University

All rights reserved

P1 **STEP 1**
Scale: 1:10

Step 1:

+ Identify the decayed plaster area

Project name and address THE TU GIAC HOUSING CONSERVATION PROTOTYPE HUE CITY, VIETNAM		Sheet No.
Name and address TRAN TUAN ANH FACULTY OF ARCHITECTURE, CHIANG MAI UNIVERSITY	Scale 1: 10	P-11.1
	Date Aug - 2008	

METHODS FOR THE DECAYED PLASTER DUE TO CLIMATIC IMPACTS

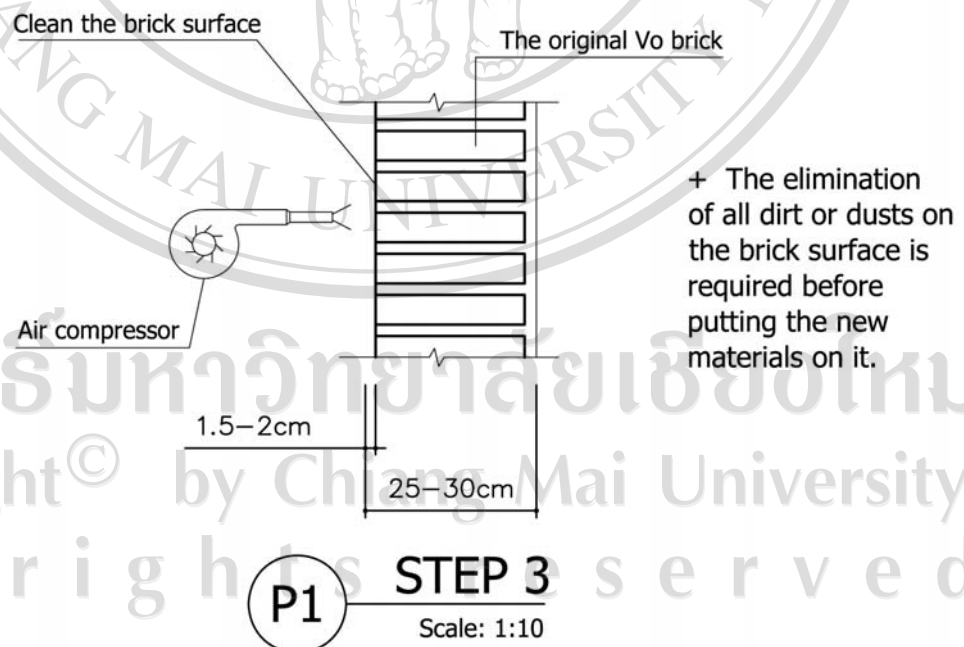
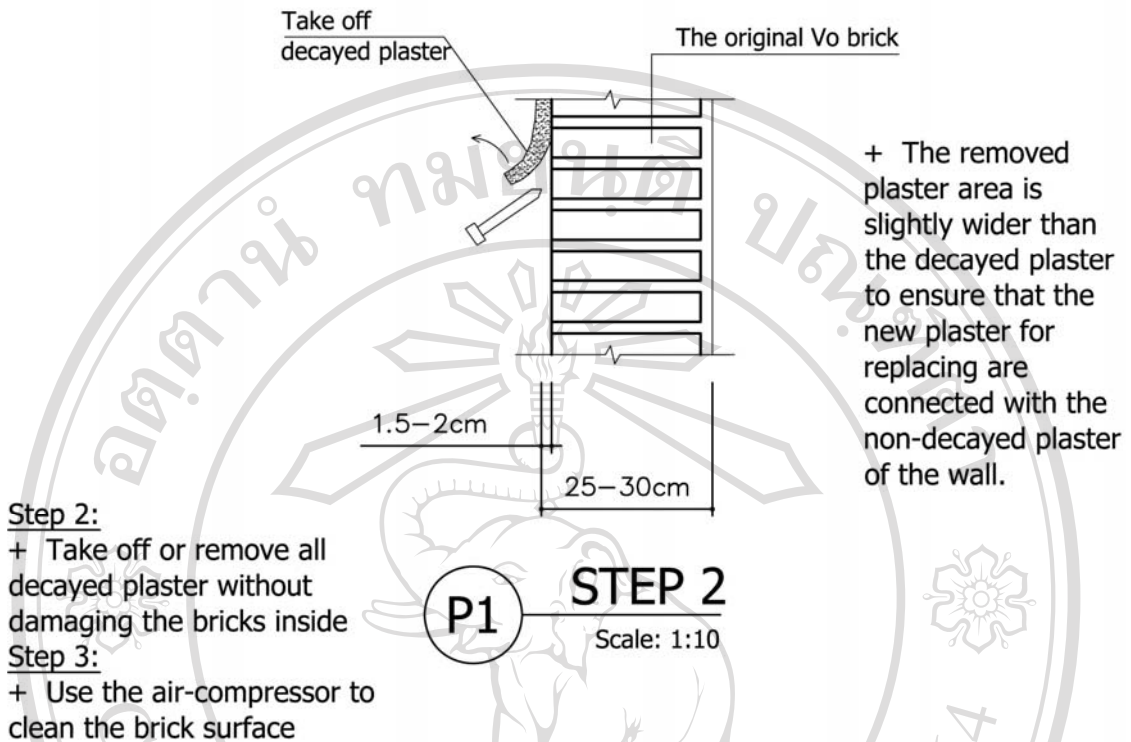

ลิขสิทธิ์มหาวิทยาลัยเชียงใหม่
 Copyright © by Chiang Mai University
 All rights reserved

Project name and address THE TU GIAC HOUSING CONSERVATION PROTOTYPE HUE CITY, VIETNAM		Sheet No.
Name and address TRAN TUAN ANH FACULTY OF ARCHITECTURE, CHIANG MAI UNIVERSITY	Scale 1: 10	P-11.2
	Date Aug - 2008	

METHODS FOR THE DECAYED PLASTER DUE TO CLIMATIC IMPACTS

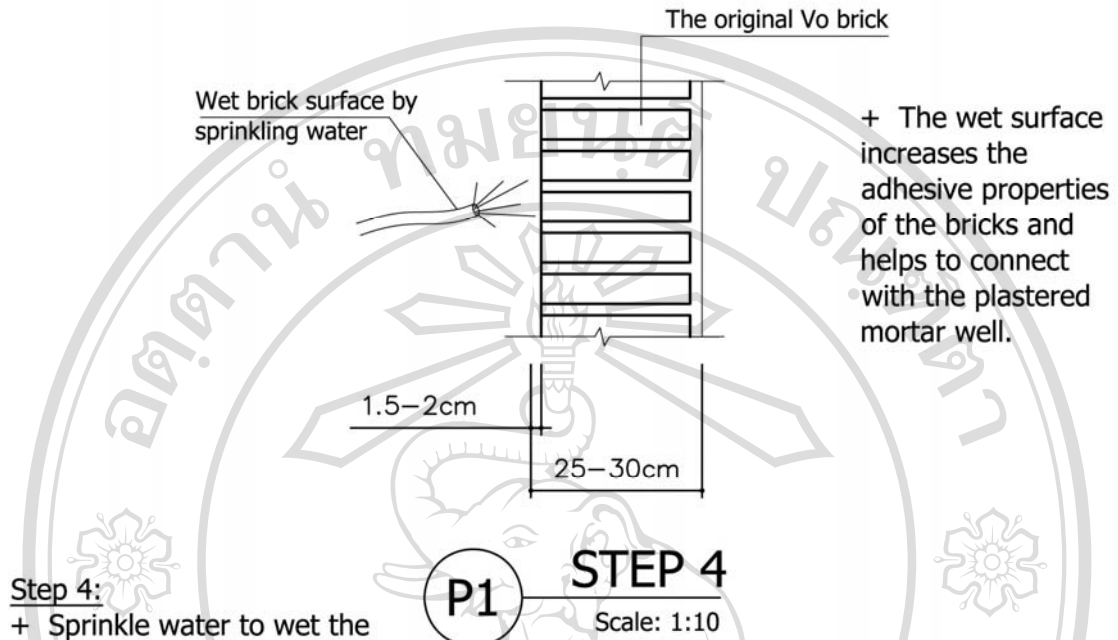

Step 4:
+ Sprinkle water to wet the brick surface

Step 5:
+ Coat the brick surface by slurry liquid to protect the brick-block of the wall

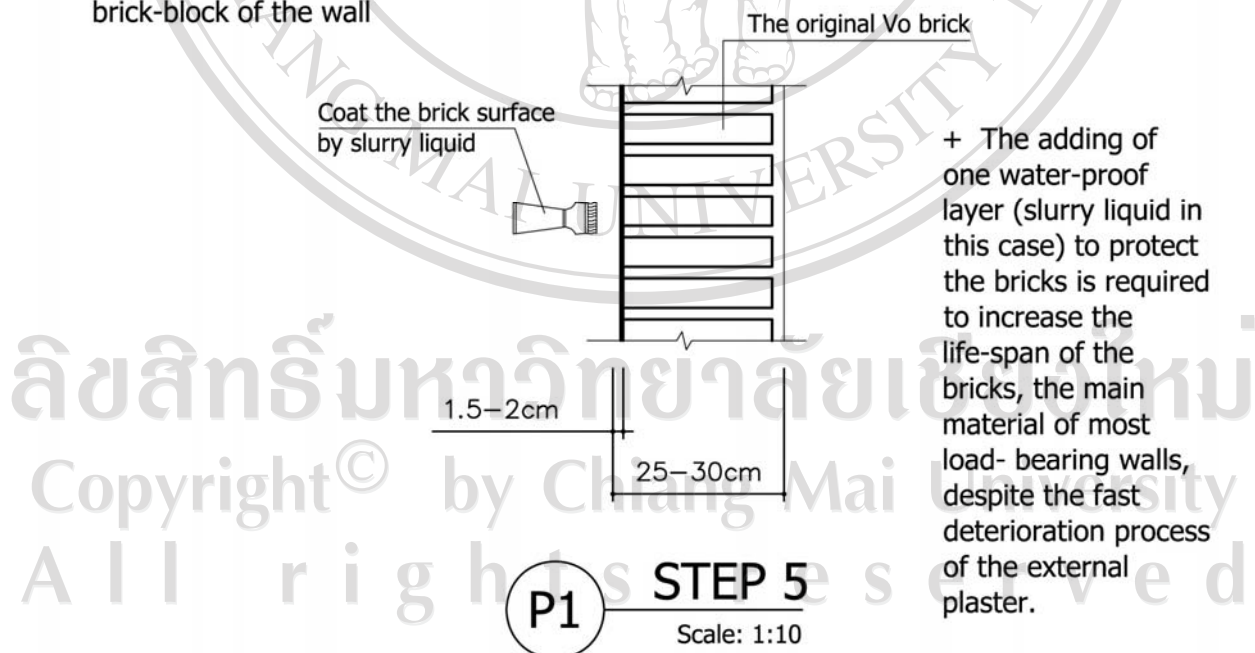

Project name and address THE TU GIAC HOUSING CONSERVATION PROTOTYPE HUE CITY, VIETNAM		Sheet No.
Name and address TRAN TUAN ANH FACULTY OF ARCHITECTURE, CHIANG MAI UNIVERSITY	Date 1: 10	P-11.3
	Date Aug - 2008	

METHODS FOR THE DECAYED PLASTER DUE TO CLIMATIC IMPACTS

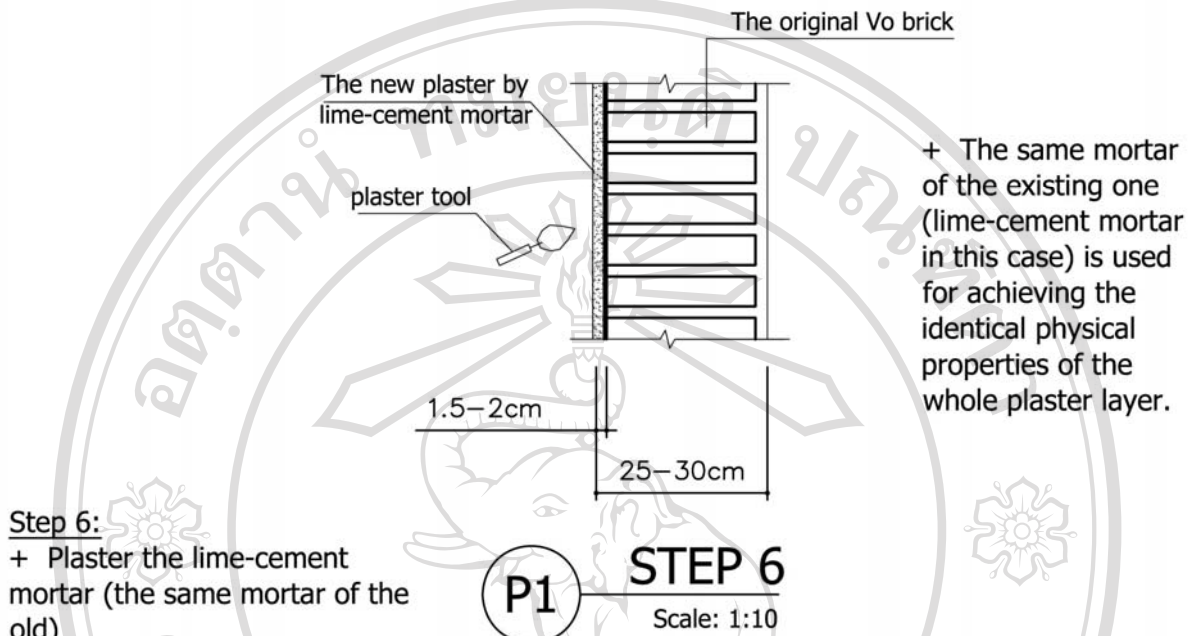

Step 6:
+ Plaster the lime-cement mortar (the same mortar of the old)

Step 7:
+ Finishing the wall by coating the white-wash with the same color of the wall

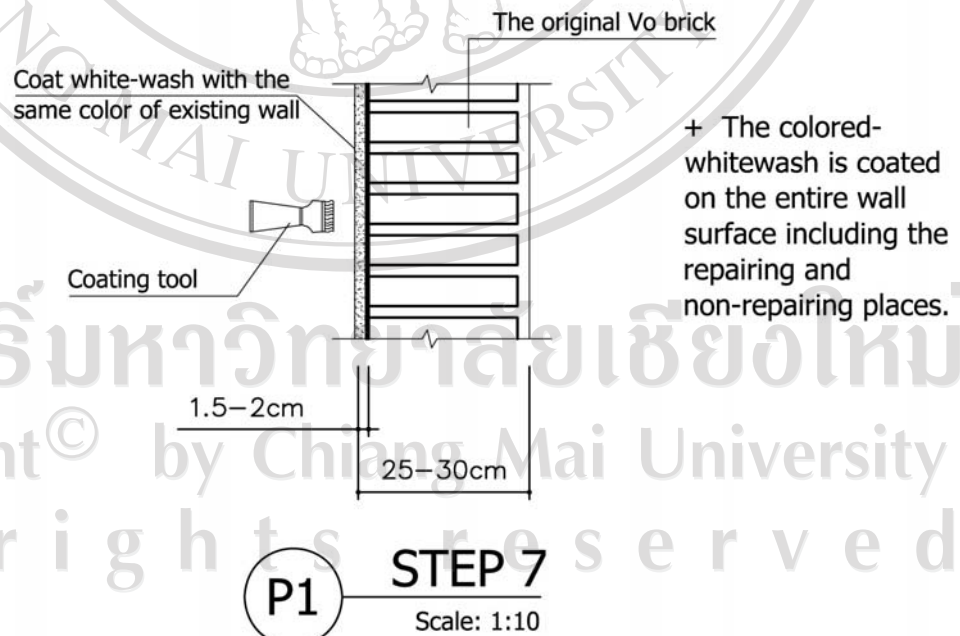

ลิขสิทธิ์มหาวิทยาลัยเชียงใหม่
Copyright © by Chiang Mai University
All rights reserved

Project name and address THE TU GIAC HOUSING CONSERVATION PROTOTYPE HUE CITY, VIETNAM		Sheet No.
Name and address TRAN TUAN ANH FACULTY OF ARCHITECTURE, CHIANG MAI UNIVERSITY	Scale 1: 10	P-11.4
	Date Aug - 2008	

METHODS FOR THE DECAYED PLASTER DUE TO ANNUAL FLOODS

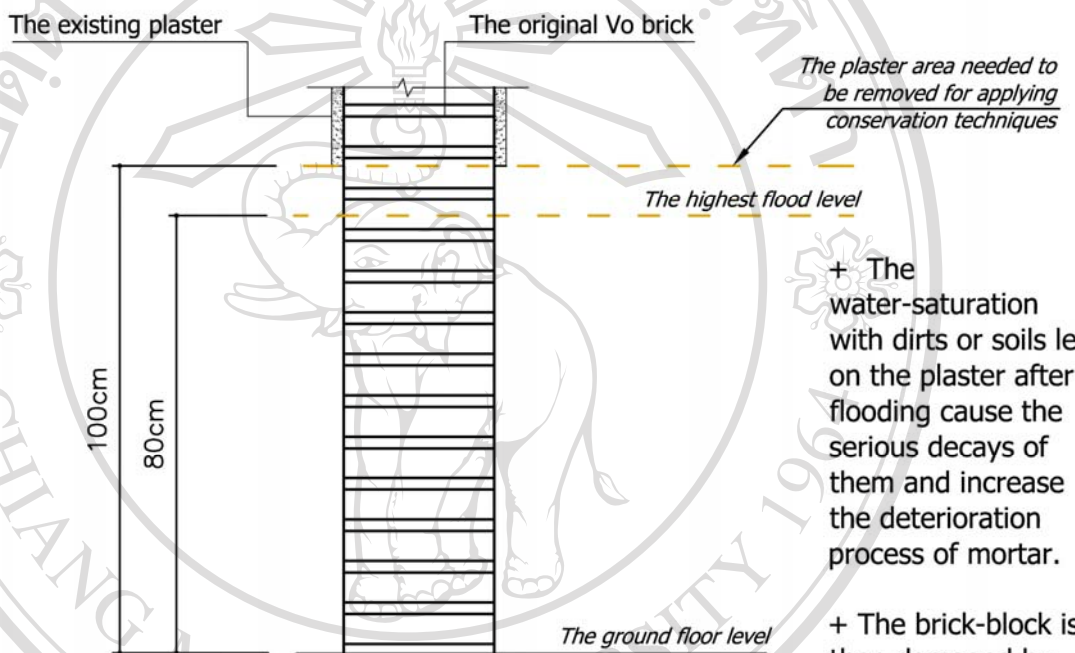

+ The water-saturation with dirts or soils left on the plaster after flooding cause the serious decays of them and increase the deterioration process of mortar.

+ The brick-block is then damaged by flood water once the plaster deteriorated.

+ The protection-area should be higher than the highest level of the annual floods to ensure the good protection of the below parts of the load-bearing walls during flooding.

P2 STEP 1

Scale: 1:10

Step 1:

- + Identify the decayed plaster area higher than the highest flood level 0.8m (*the limit line of plaster for removing is 1m high from the floor level*)
- + Remove all decayed plaster

Project name and address THE TU GIAC HOUSING CONSERVATION PROTOTYPE HUE CITY, VIETNAM		Sheet No.
Name and address TRAN TUAN ANH FACULTY OF ARCHITECTURE, CHIANG MAI UNIVERSITY	Scale 1: 10	P-12.1
	Date Aug - 2008	

METHODS FOR THE DECAYED PLASTER DUE TO ANNUAL FLOODS

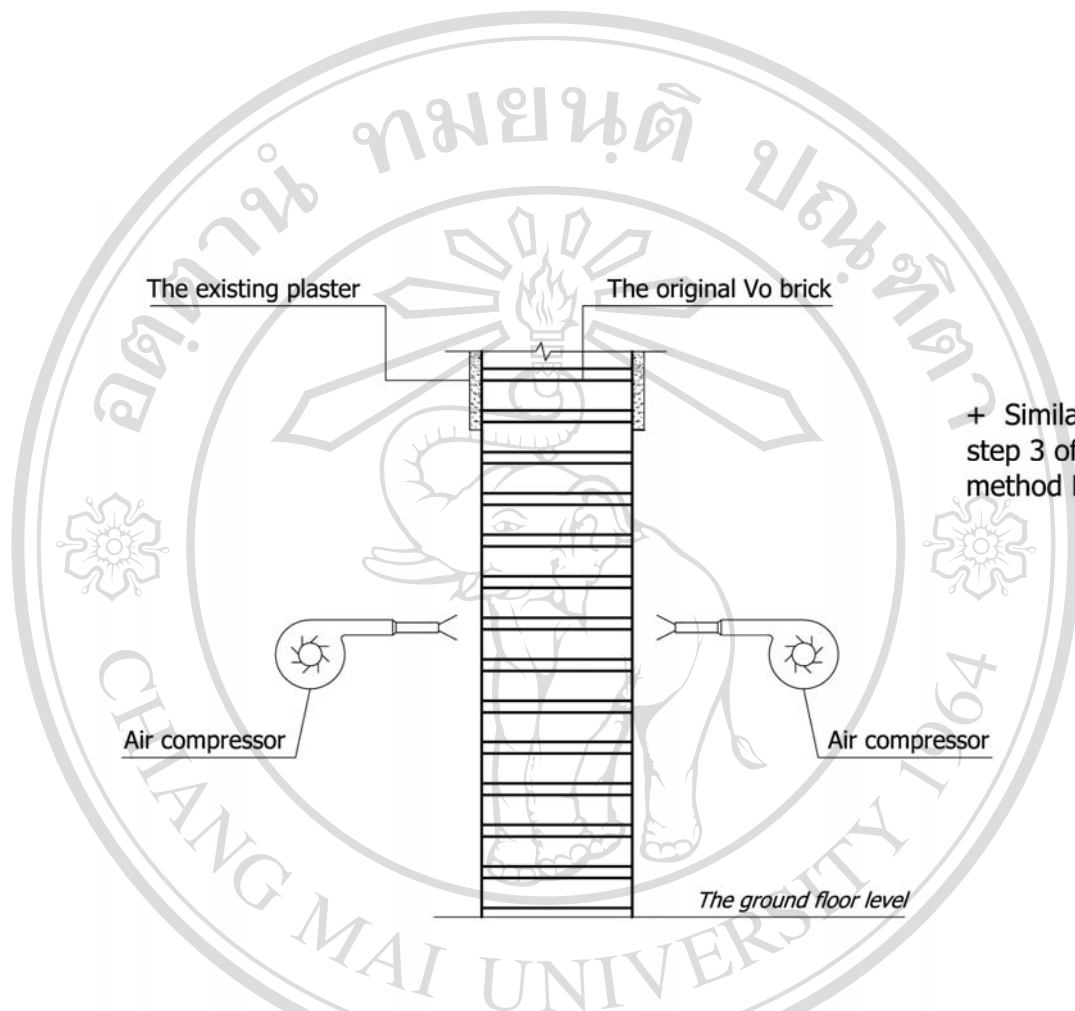

+ Similar to the step 3 of the method **P1**.

P2 **STEP 2**
Scale: 1:10

ลิขสิทธิ์มหาวิทยาลัยเชียงใหม่

Copyright © by Chiang Mai University

All rights reserved

Step 2:
+ Use the air-compressor to clean the brick surface

Project name and address THE TU GIAC HOUSING CONSERVATION PROTOTYPE HUE CITY, VIETNAM		Sheet No.
Name and address TRAN TUAN ANH FACULTY OF ARCHITECTURE, CHIANG MAI UNIVERSITY	Scale 1: 10	P-12.2
	Date Aug - 2008	

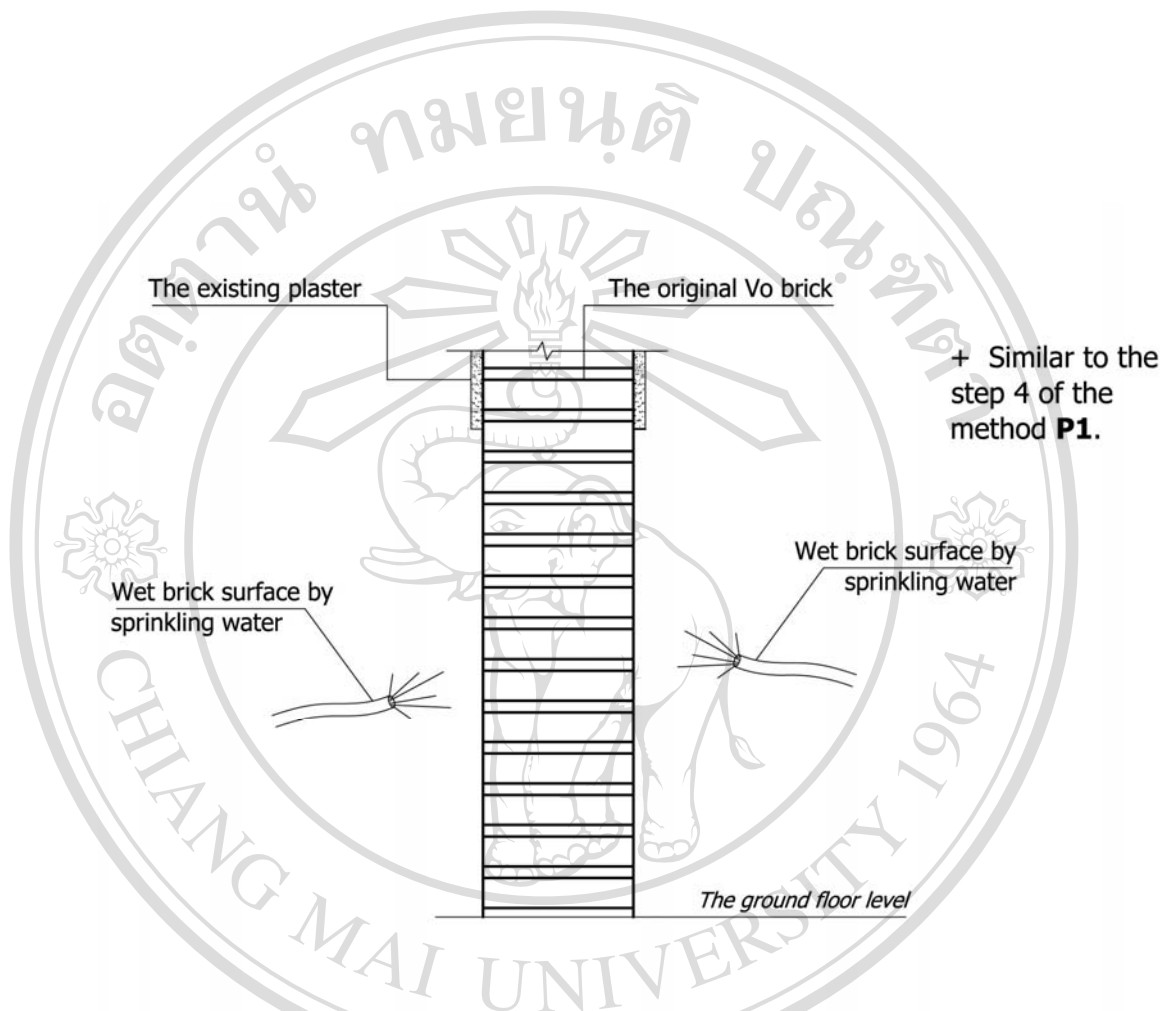

P2 **STEP 3**
Scale: 1:10

ลิขสิทธิ์มหาวิทยาลัยเชียงใหม่
Copyright © by Chiang Mai University
All rights reserved

Project name and address THE TU GIAC HOUSING CONSERVATION PROTOTYPE HUE CITY, VIETNAM		Sheet No.
Name and address TRAN TUAN ANH FACULTY OF ARCHITECTURE, CHIANG MAI UNIVERSITY	Scale 1: 10	P-12.3
	Date Aug - 2008	

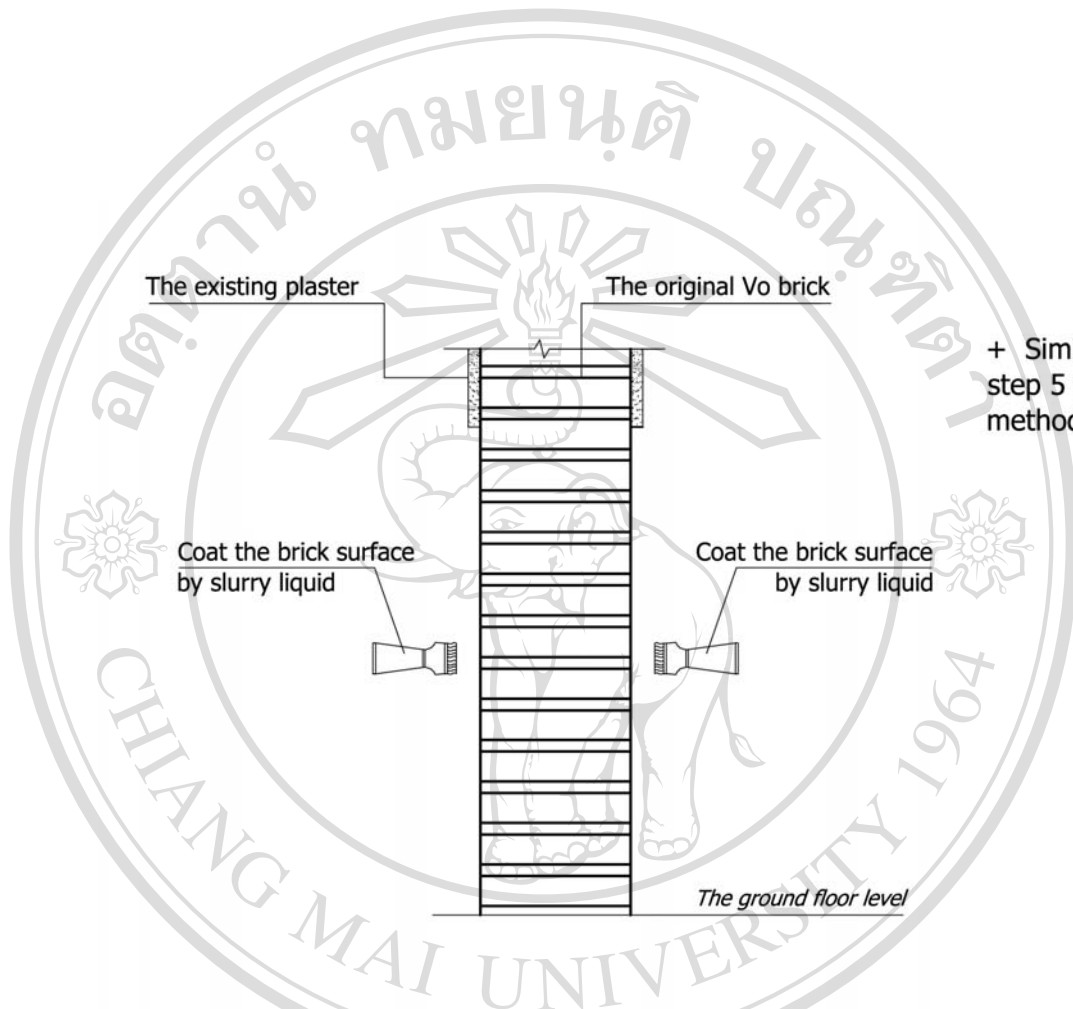

+ Similar to the step 5 of the method **P1**.

P2 **STEP 4**
Scale: 1:10

ลิขสิทธิ์มหาวิทยาลัยเชียงใหม่
Copyright © by Chiang Mai University
All rights reserved

Step 4:
+ Coat the brick surface by slurry liquid to protect the brick-block of the wall

Project name and address THE TU GIAC HOUSING CONSERVATION PROTOTYPE HUE CITY, VIETNAM		Sheet No.
Name and address TRAN TUAN ANH FACULTY OF ARCHITECTURE, CHIANG MAI UNIVERSITY	Scale 1: 10	P-12.4
	Date Aug - 2008	

METHODS FOR THE DECAYED PLASTER DUE TO ANNUAL FLOODS

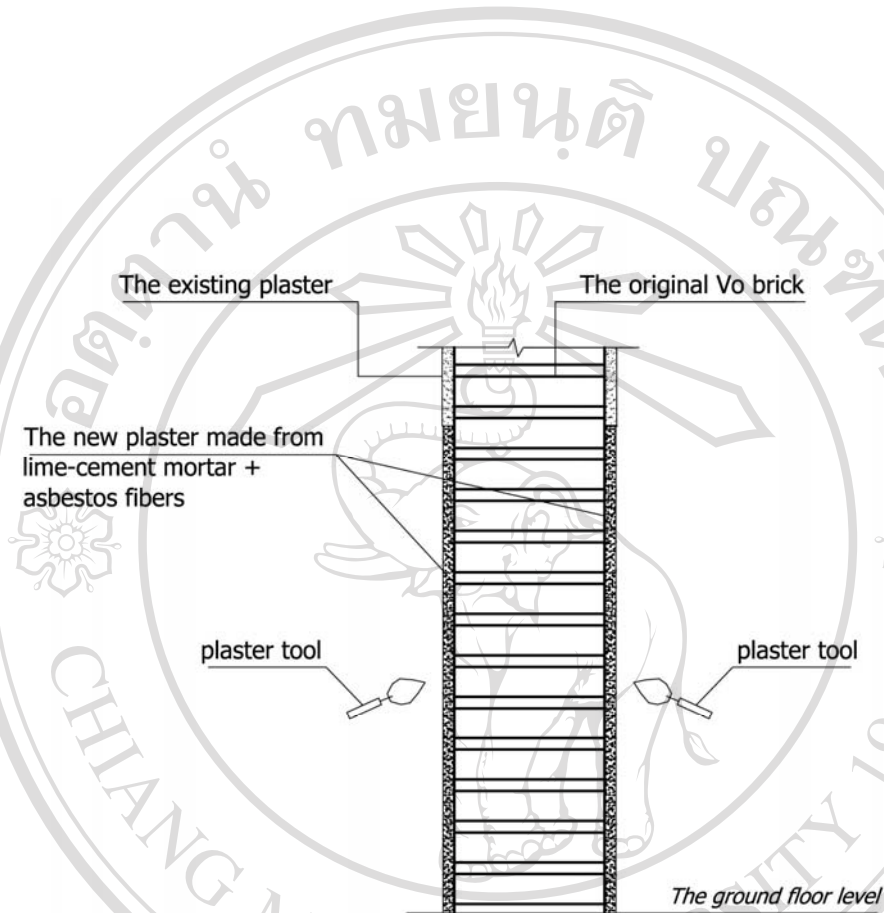

+ Due to the strongly destructive cause of the flood water, the new repairing mortar should be mixed with the net-formed material (asbestos fibers in this case) to increase the cohesion of material and the water-resistant character of the new plaster.

P2

STEP 5

Scale: 1:10

ลิขสิทธิ์มหาวิทยาลัยเชียงใหม่

Copyright © by Chiang Mai University

All rights reserved

Step 5:

+ Plaster the new mortar which is made from the lime-cement mortar mixed with asbestos fibers for moisture-resistance

Project name and address THE TU GIAC HOUSING CONSERVATION PROTOTYPE HUE CITY, VIETNAM		Sheet No.
Name and address TRAN TUAN ANH FACULTY OF ARCHITECTURE, CHIANG MAI UNIVERSITY	Scale 1: 10	P-12.5
	Date Aug - 2008	

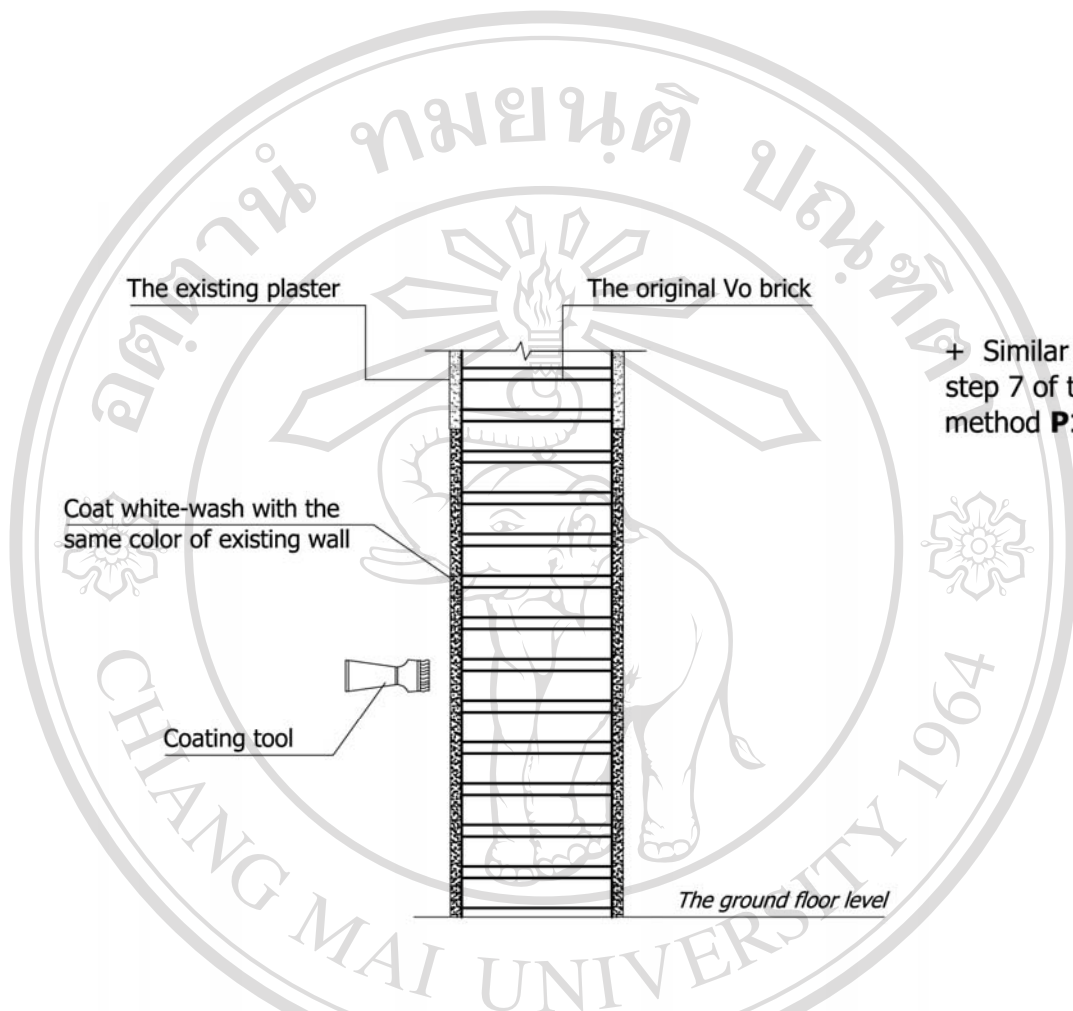

+ Similar to the step 7 of the method **P1**.

P2 **STEP 6**
Scale: 1:10

ลิขสิทธิ์มหาวิทยาลัยเชียงใหม่
Copyright © by Chiang Mai University
All rights reserved

Step 6:
+ Finishing the wall by coating the white-wash with the same color of the existing walls

Project name and address THE TU GIAC HOUSING CONSERVATION PROTOTYPE HUE CITY, VIETNAM		Sheet No.
Name and address TRAN TUAN ANH FACULTY OF ARCHITECTURE, CHIANG MAI UNIVERSITY	Scale 1: 10	P-12.6
	Date Aug - 2008	

METHODS FOR THE CRACKS > 5MM WIDTH ON THE TIMBER BEAMS AND BARS

+ The big crack > 5mm width is normally caused by the insufficient strength of timber elements in carrying load. The crack is long and has wide and deep opening. It affects directly to the inner core of the timber and reduce its strength. It develops through time and threaten the collapse. It is the structural failure of the timber elements. Therefore, the structural repairs are essential in this case.

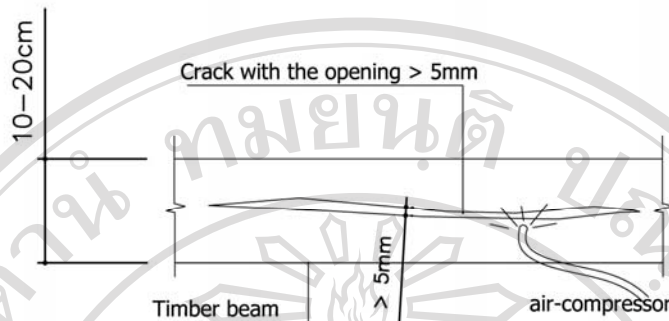

T1 **STEP 1**
Scale: 1:10

Create the fishtail-shaped holes according to the width of crack at each position

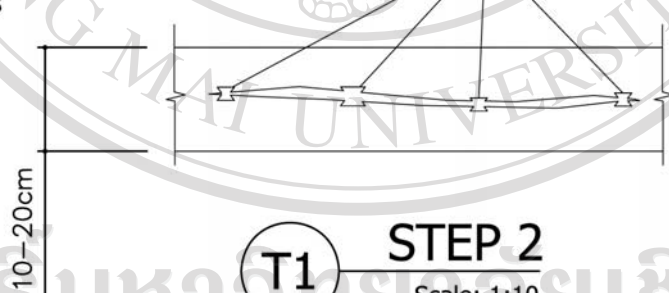

T1 **STEP 2**
Scale: 1:10

- Step 1:**
- + Identify the crack with its opening > 5mm
 - + Clean the crack by the air-compressor
- Step 2:**
- + Create the fishtail-shaped holes on the crack. The size of the holes depends on the width of the crack at each specific position

+ *Structural repairs* comprise metallic or non-metallic reinforcements. The principle is to remove some damaged wood from the member by creating holes or channels. Metallic or non-metallic reinforcement materials are inserted into voids and the epoxy is filled in afterward to adhere and consolidate the decayed wood. The metallic reinforcement material method is suitable for the serious decayed timbers, such as, the broken of one part of timbers or the long and big cracks surrounding the timbers. The non-metallic reinforcement material method is used to fix the timbers which have less level of deterioration, such as, the crack on one side of timber beam or column.

+ The study has applied the *non-metallic reinforcement material method* to repair the timber elements of *Tu Giac* houses.

Project name and address THE TU GIAC HOUSING CONSERVATION PROTOTYPE HUE CITY, VIETNAM		Sheet No.
Name and address TRAN TUAN ANH FACULTY OF ARCHITECTURE, CHIANG MAI UNIVERSITY	Scale 1: 10	P-13.1
	Date Aug - 2008	

METHODS FOR THE CRACKS > 5MM WIDTH ON THE TIMBER BEAMS AND BARS

+ *Adhesive methods* are the newest repair techniques and have successful applications for structural situations. Advances in Epoxy resin in adhesive repair techniques have achieved effectively in the conservation of wood structures.

+ Epoxy resins are available as low viscosity liquid or high viscosity putty or paste.

+ The low viscosity liquids penetrate cracks and and reinforce the weakened wood.

+ The high viscosity putty or paste is used to replace missing wood by building up forming it into the desired shape. Trowel or similar tool is used to fill it into cracks.

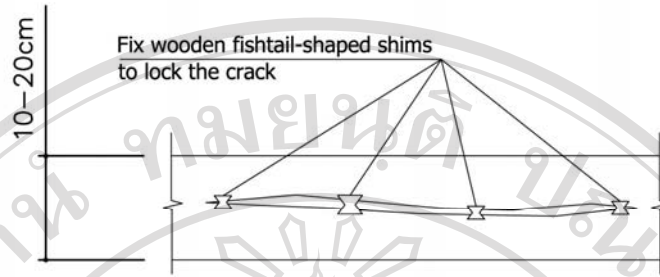

T1 **STEP 3**
Scale: 1:10

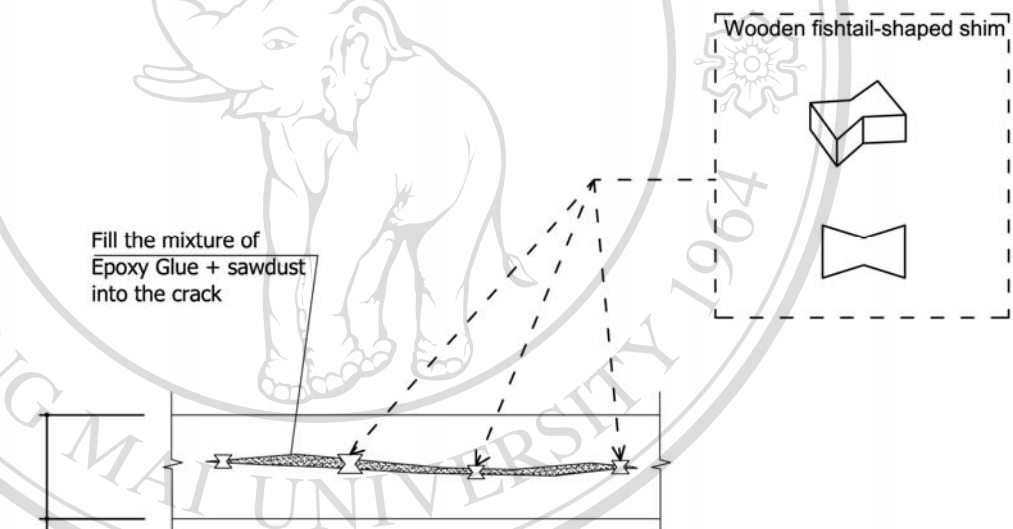

T1 **STEP 4**
Scale: 1:10

- Step 3:**
- + Create the wooden fishtail-shaped shims whose size is slightly smaller than the size of the fishtail-shaped holes.
 - + Lock the cracks by fixing those shims on the beam.
- Step 4:**
- + Fill the mixture of Epoxy resin (high viscosity paste) and sawdust into the crack and finish the wood surface on the crack

Project name and address THE TU GIAC HOUSING CONSERVATION PROTOTYPE HUE CITY, VIETNAM		Sheet No.
Name and address TRAN TUAN ANH FACULTY OF ARCHITECTURE, CHIANG MAI UNIVERSITY	Scale 1: 10	P-13.2
	Date Aug - 2008	

METHODS FOR THE CRACKS < 5MM WIDTH ON THE TIMBER BEAMS

+ The *injection method* is used to fill cracks since Epoxy is a good gap-filling material.

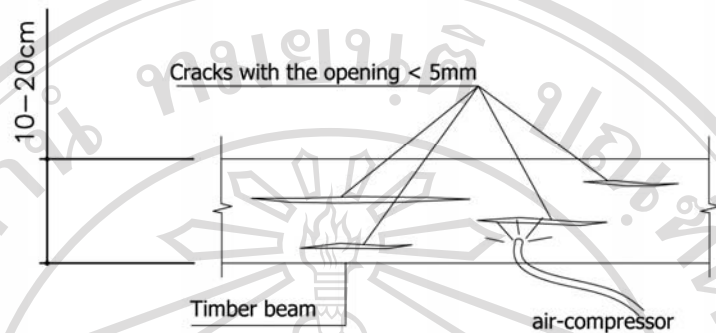

+ The small cracks < 5mm width are usually caused by thermal expansion and contraction of wood when the temperature changes.

+ These cracks do not affect directly the strength of the timber elements but, indirectly, they provide good condition for fungi or pests or moisture to attack the inner core of timber elements.

+ The closing of the cracks by filling with adhesive materials is vital to prevent those attacks.

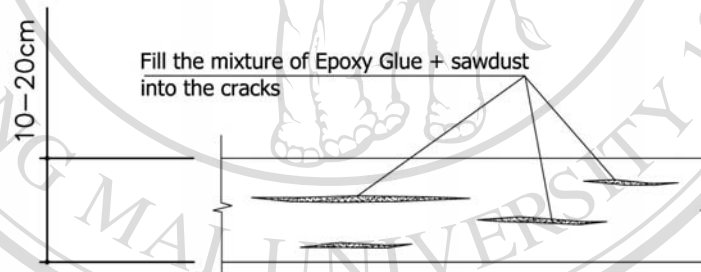

ลิขสิทธิ์มหาวิทยาลัยเชียงใหม่
Copyright © by Chiang Mai University
All rights reserved

Step 1:

- + Identify the crack with its opening < 5mm
- + Clean the crack by the air-compressor

Step 2:

- + Fill in the cracks by the mixture of Epoxy resin and sawdust, and then finish

Project name and address THE TU GIAC HOUSING CONSERVATION PROTOTYPE HUE CITY, VIETNAM		Sheet No.
Name and address TRAN TUAN ANH FACULTY OF ARCHITECTURE, CHIANG MAI UNIVERSITY	Scale 1: 10	P-14
	Date Aug - 2008	

METHODS FOR THE CRACKS ON THE MASONRY ROOF RIDGES

Roof ridges on the hip roof

Cracks on the roof ridges

Liet tiles cover

+ The stitching of the cracks by the metallic elements is the selected method to repair the cracks on the top of roof ridges. The steel rods are added to stitch on the top area for achieving the reinforcement of the roof ridges.

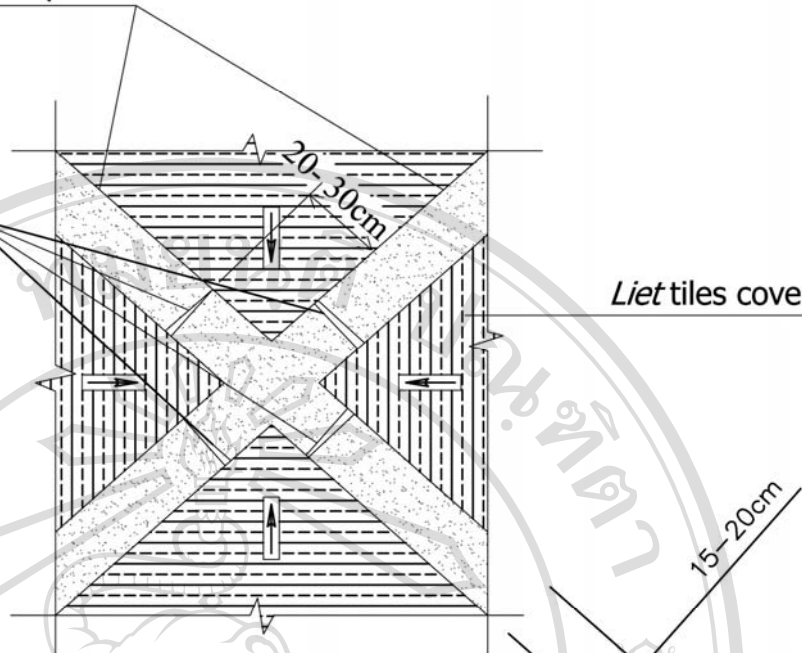

R1 **STEP 1**
Scale: 1:20

+ The cracks are generally caused by the tendency of sliding down of the hip roof. Due to being connected on the top, it leads to the cracks on the top part of 4 masonry roof-ridges.

Remove mortar and clean the roof ridges

Step 1:
+ Identify the cracks of the roof ridges on the top (around 20-30cm distance)

Step 2:
+ Take off all mortar of the roof ridges which cover all the cracks
+ Clean the surfaces of the roof ridges after removing mortar and wet them by water

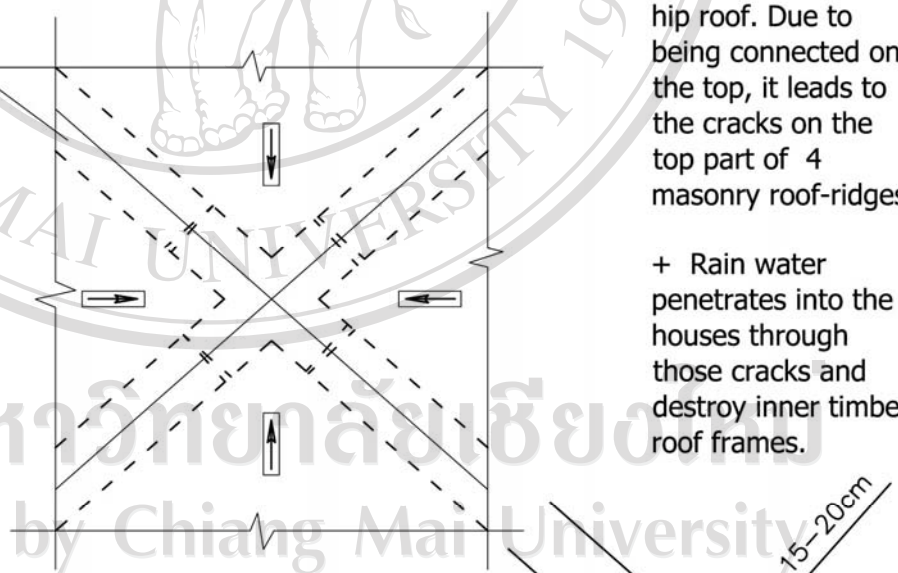

R1 **STEP 2**
Scale: 1:20

+ Rain water penetrates into the houses through those cracks and destroy inner timber roof frames.

Project name and address THE TU GIAC HOUSING CONSERVATION PROTOTYPE HUE CITY, VIETNAM		Sheet No.
Name and address TRAN TUAN ANH FACULTY OF ARCHITECTURE, CHIANG MAI UNIVERSITY	Scale 1: 20	P-15.1
	Date Aug - 2008	

METHODS FOR THE CRACKS ON THE MASONRY ROOF RIDGES

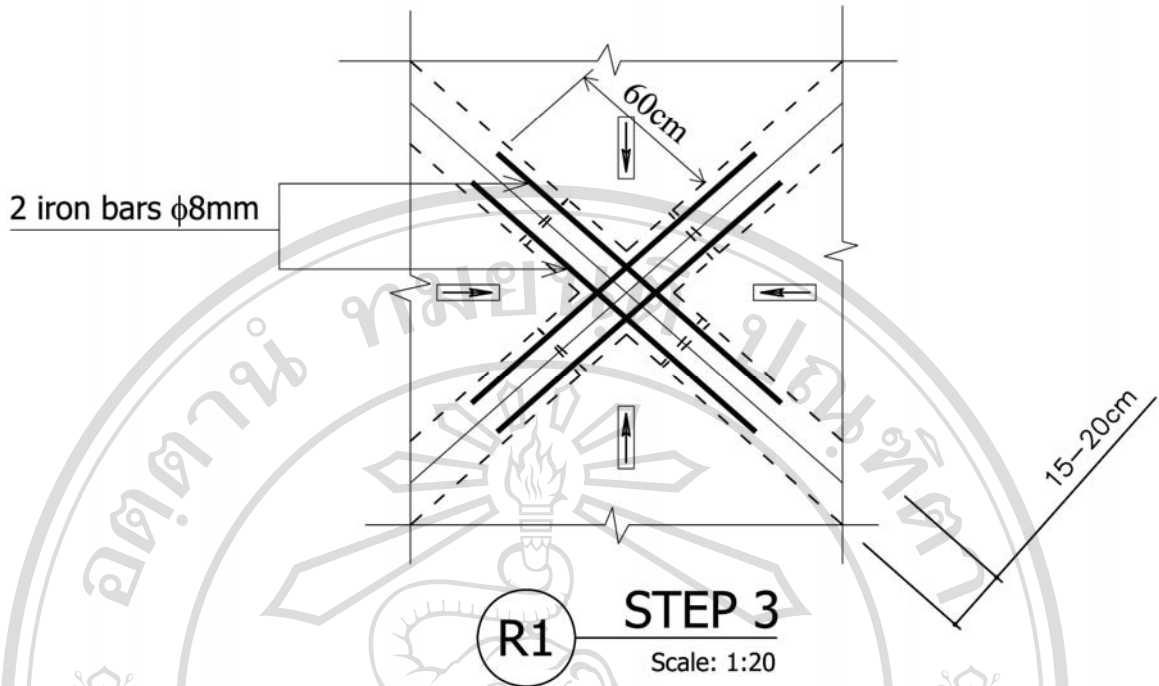

Refill the roof ridges by the new traditional mortar

Step 3:

+ Put 2 iron bars $\phi 8\text{mm}$ crossing the peak to connect 2 opposite ridges. The extension of the iron bars is over the crack (about 60cm) for rejoining the crack

Step 4:

+ Rebuild the roof ridges with the new traditional mortar

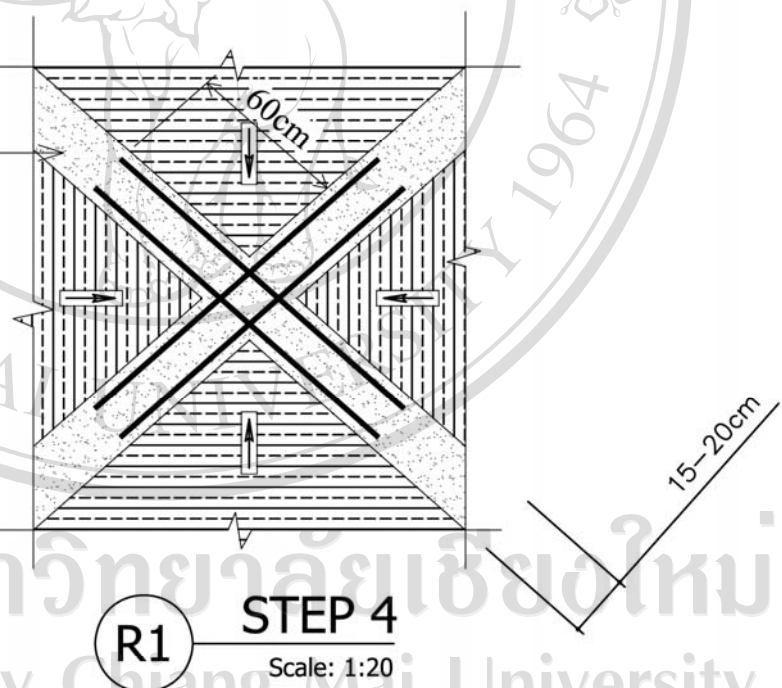

The formula of traditional mortar used for roof ridges:

Traditional mortar	Portland Cement 30	White cement	Lime powder	Paper fibers	Sand	Additive	Black powder	Green powder	Water/Cement
1000 (kg)	192.7	128.4	137.6	19.3	481.6	2.8	32.1	6.4	0.84

Project name and address THE TU GIAC HOUSING CONSERVATION PROTOTYPE HUE CITY, VIETNAM		Sheet No.
Name and address TRAN TUAN ANH FACULTY OF ARCHITECTURE, CHIANG MAI UNIVERSITY	Scale 1: 20	P-15.2
	Date Aug - 2008	

METHODS FOR THE DECAYED ENDPOINTS OF THE HIGH-PITCH TIMBER STAIR

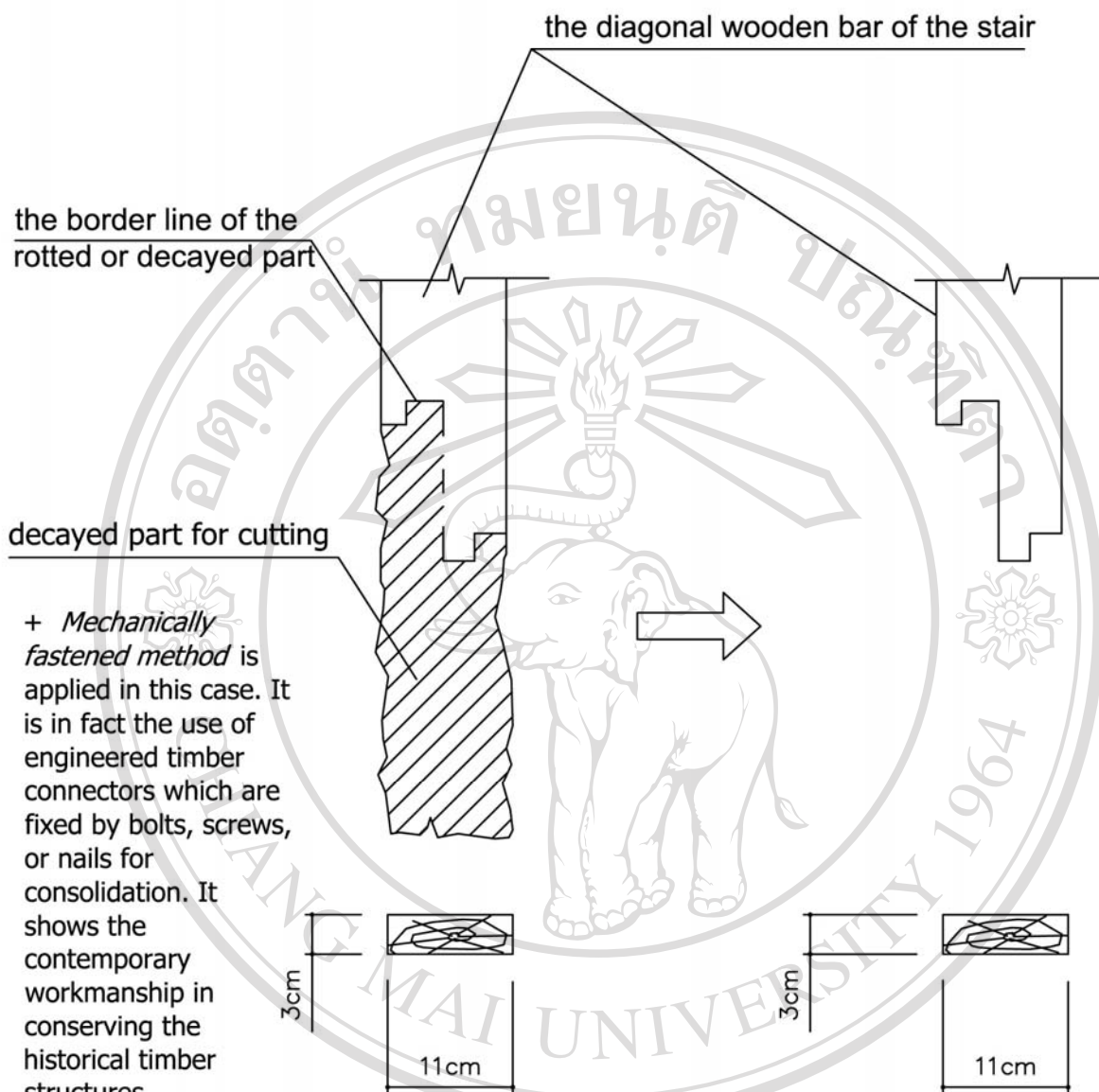

S1 — **STEP 1**
Scale: 1:5

S1 — **STEP 2**
Scale: 1:5

Step 1:

+ Define the decayed endpoints by the border line on two high-pitch timber bars of the stair

Step 2:

+ Cut the decayed endpoints following the border line

Project name and address THE TU GIAC HOUSING CONSERVATION PROTOTYPE HUE CITY, VIETNAM		Sheet No.
Name and address TRAN TUAN ANH FACULTY OF ARCHITECTURE, CHIANG MAI UNIVERSITY	Scale 1: 5	P-16.1
	Date Aug - 2008	

METHODS FOR THE DECAYED ENDPOINTS OF THE HIGH-PITCH TIMBER STAIR

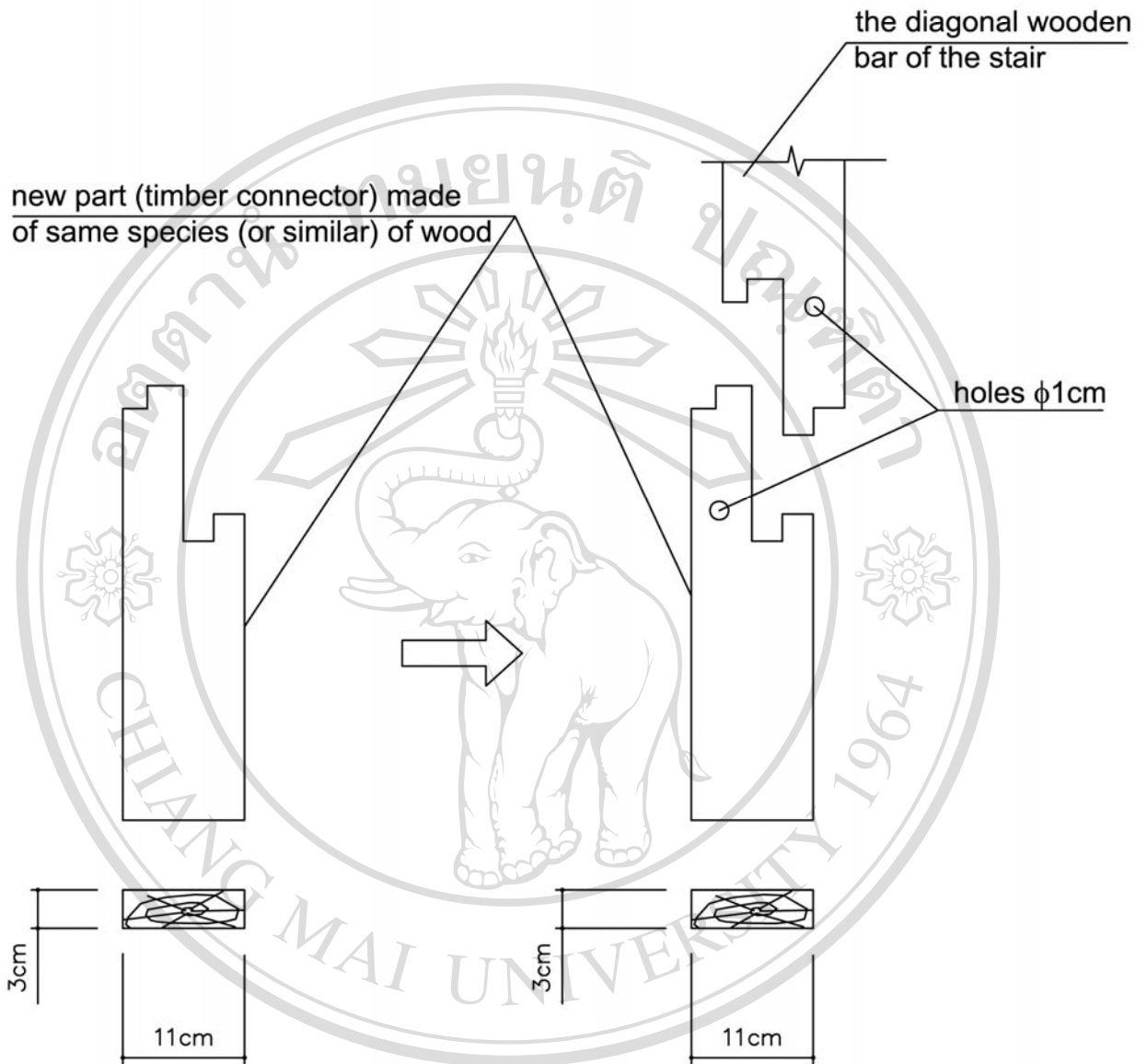

S1

STEP 3

Scale: 1:5

Step 3:

+ Create the new parts with the same species of wood being replaced.

The width and thickness of the new part is 1-2mm bigger than the old ones due to its contraction with the passing of time. The new wooden parts must have the moisture content 13-15%

+ Boring two holes $\Phi 1\text{cm}$ on the existing wooden bar of the stair and on the new part

Project name and address THE TU GIAC HOUSING CONSERVATION PROTOTYPE HUE CITY, VIETNAM		Sheet No.
Name and address TRAN TUAN ANH FACULTY OF ARCHITECTURE, CHIANG MAI UNIVERSITY	Scale 1: 5	P-16.2
	Date Aug - 2008	

METHODS FOR THE DECAYED ENDPOINTS OF THE HIGH-PITCH TIMBER STAIR

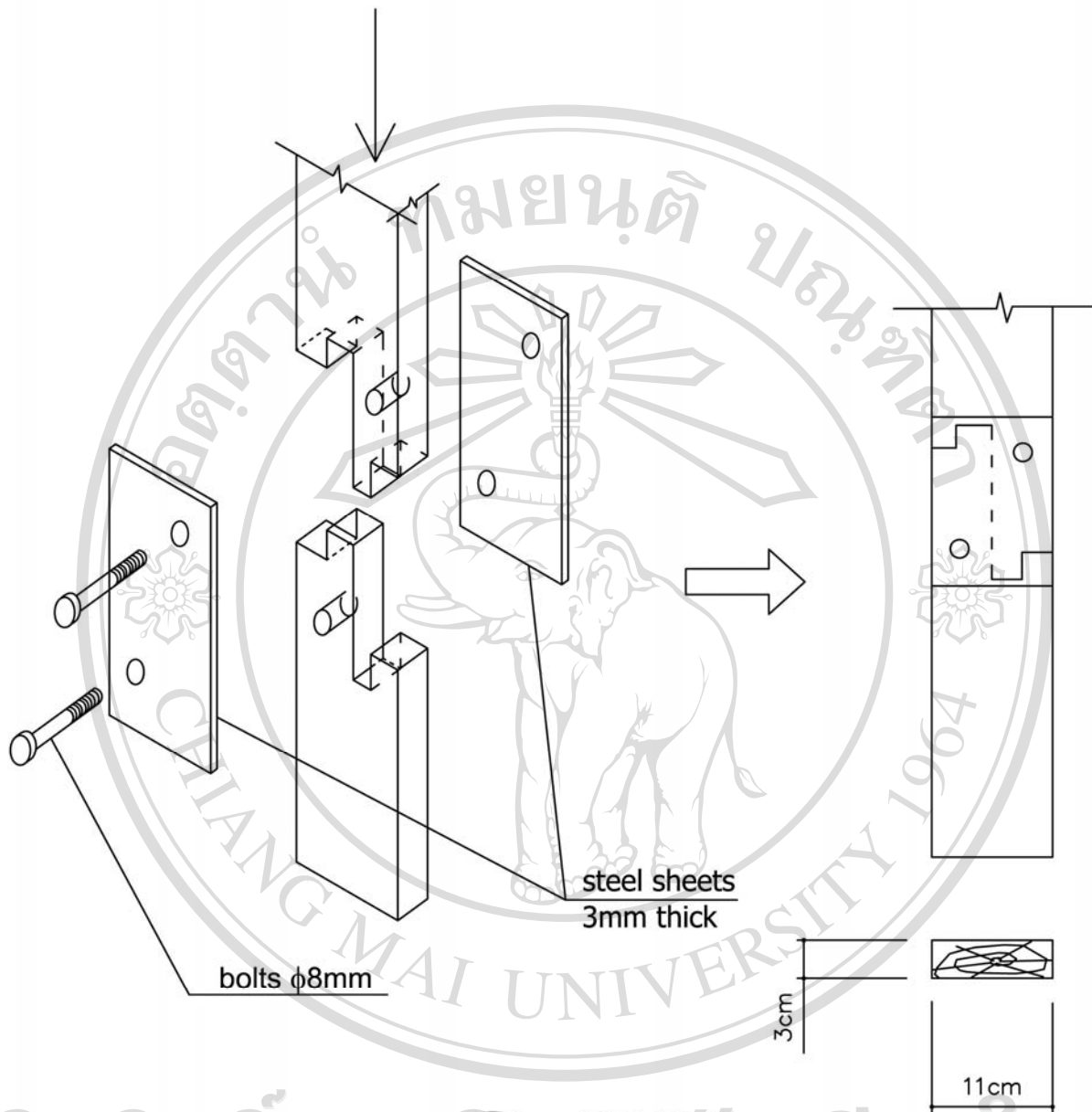

S1 **STEP 4**
Scale: 1:5

ลิขสิทธิ์มหาวิทยาลัยเชียงใหม่
Copyright © by Chiang Mai University
All rights reserved

Step 4:

- + Assemble the new part to the stair
- + Fix two steel sheets 3mm-thickness by two bolts $\phi 8\text{mm}$ to stabilize them

Project name and address THE TU GIAC HOUSING CONSERVATION PROTOTYPE HUE CITY, VIETNAM		Sheet No.
Name and address TRAN TUAN ANH FACULTY OF ARCHITECTURE, CHIANG MAI UNIVERSITY	Scale 1: 5	P-16.3
	Date Aug - 2008	

METHODS FOR THE DECAYED ENDPOINTS OF THE HIGH-PITCH TIMBER STAIR

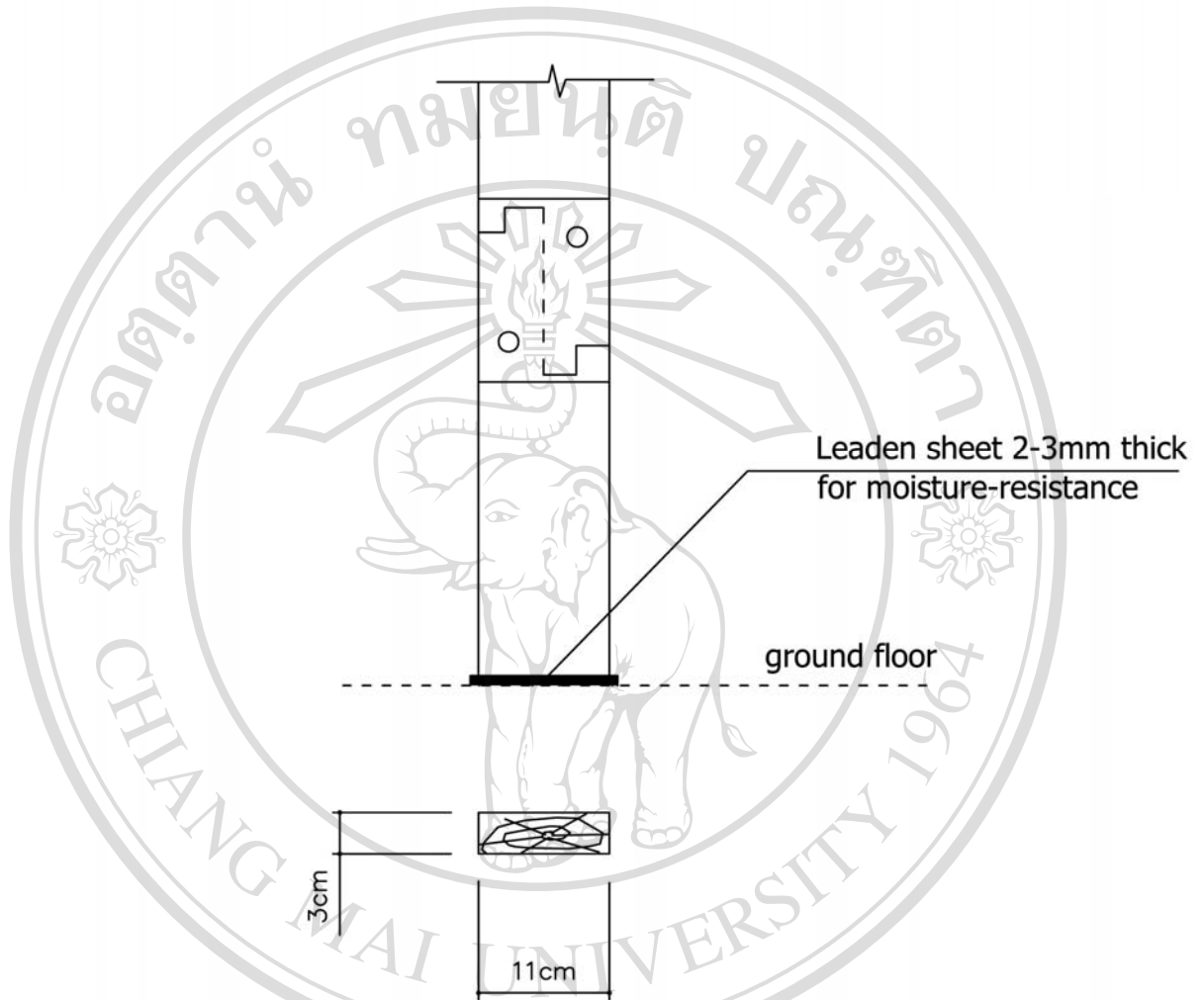

S1 **STEP 5**
Scale: 1:5

ลิขสิทธิ์มหาวิทยาลัยเชียงใหม่
Copyright © by Chiang Mai University
All rights reserved

Step 5:

+ Fix the leaden sheet 2-3mm thickness at the bottom of the endpoints of the stair which contact the ground floor to resist moisture-penetration from the ground

Project name and address THE TU GIAC HOUSING CONSERVATION PROTOTYPE HUE CITY, VIETNAM		Sheet No.
Name and address TRAN TUAN ANH FACULTY OF ARCHITECTURE, CHIANG MAI UNIVERSITY	Scale 1: 5	P-16.4
	Date Aug - 2008	

METHODS FOR THE DECAYED ENDPOINTS OF THE TIMBER PLANKS OF THE FLOOR

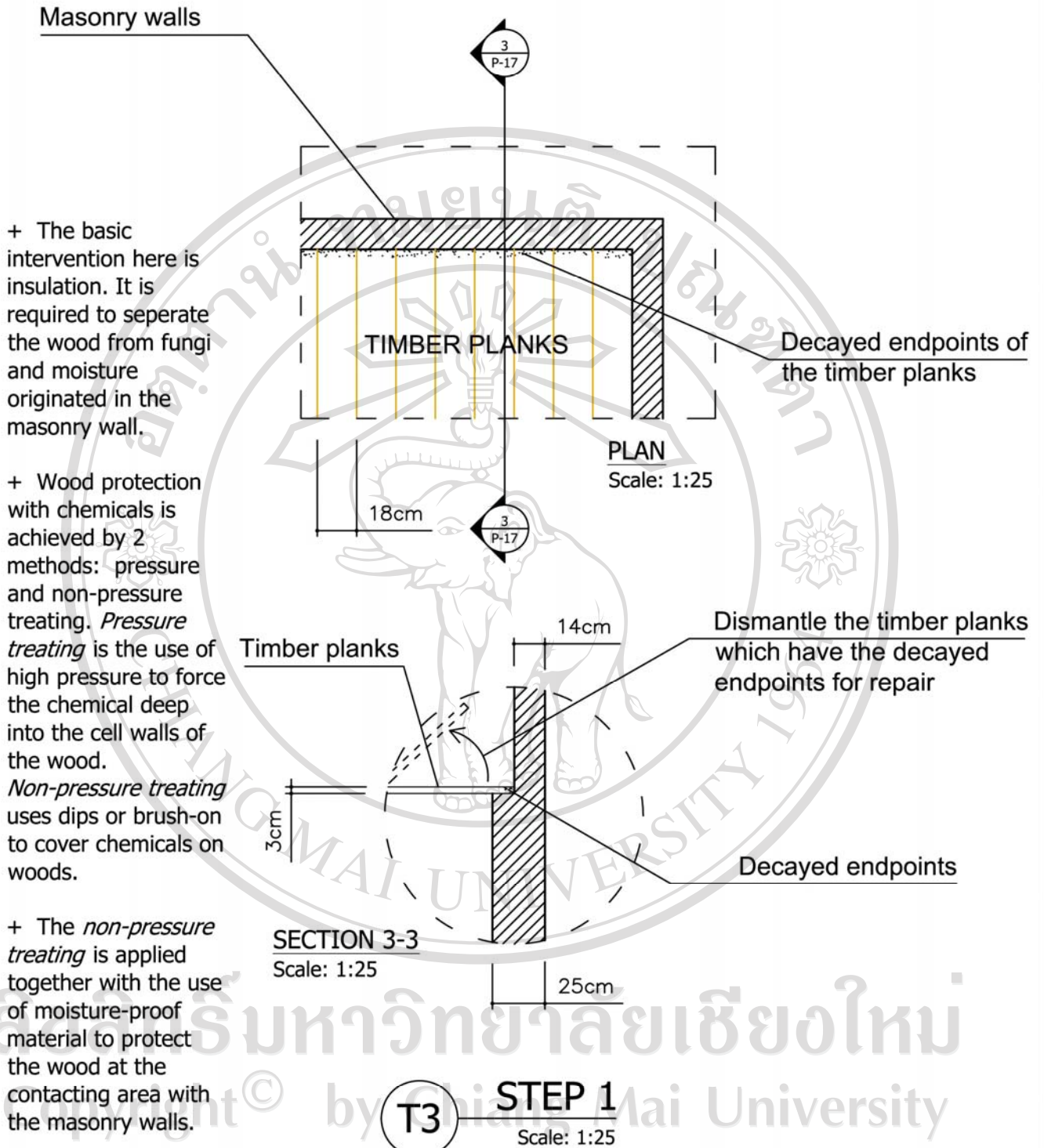

+ The basic intervention here is insulation. It is required to separate the wood from fungi and moisture originated in the masonry wall.

+ Wood protection with chemicals is achieved by 2 methods: pressure and non-pressure treating. *Pressure treating* is the use of high pressure to force the chemical deep into the cell walls of the wood. *Non-pressure treating* uses dips or brush-on to cover chemicals on woods.

+ The *non-pressure treating* is applied together with the use of moisture-proof material to protect the wood at the contacting area with the masonry walls.

Step 1:
+ Dismantle the timber planks carefully which have the decay endpoints for repairing

Project name and address THE TU GIAC HOUSING CONSERVATION PROTOTYPE HUE CITY, VIETNAM		Sheet No.
Name and address TRAN TUAN ANH FACULTY OF ARCHITECTURE, CHIANG MAI UNIVERSITY	Scale 1: 25	P-17.1
	Date Aug - 2008	

METHODS FOR THE DECAYED ENDPOINTS OF THE TIMBER PLANKS OF THE FLOOR

Remove all rots at the endpoints

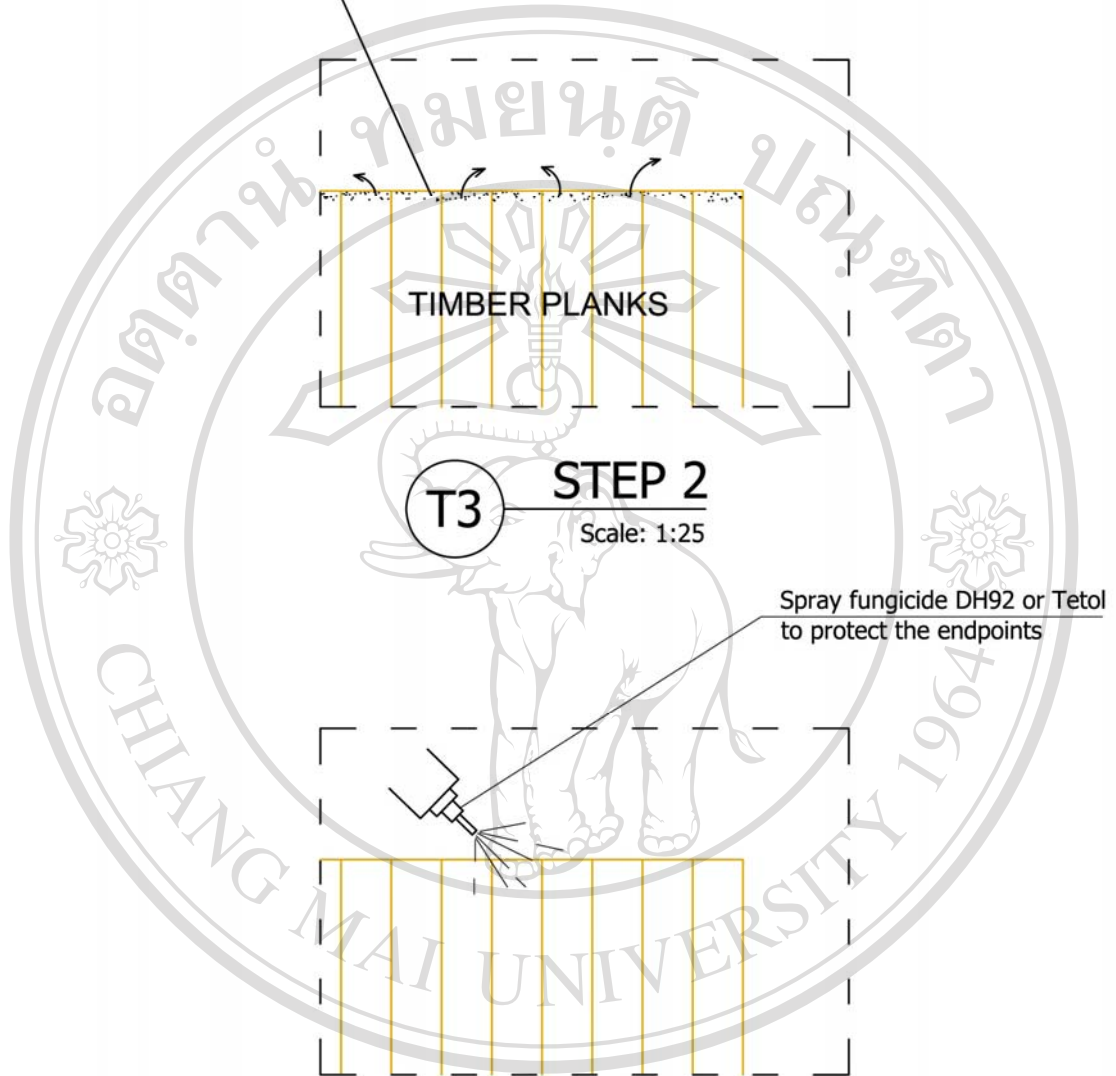

ลิขสิทธิ์มหาวิทยาลัยเชียงใหม่

Copyright © by Chiang Mai University

All rights reserved

Step 2:

+ Take off all rots at the endpoints and clean them

Step 3:

+ Spray the fungicide DH92 or Tetol on the endpoints of timber planks with the required amount 0,5litre /m2

Project name and address THE TU GIAC HOUSING CONSERVATION PROTOTYPE HUE CITY, VIETNAM		Sheet No.
Name and address TRAN TUAN ANH FACULTY OF ARCHITECTURE, CHIANG MAI UNIVERSITY	Scale 1: 25	P-17.2
	Date Aug - 2008	

METHODS FOR THE DECAYED ENDPOINTS OF THE TIMBER PLANKS OF THE FLOOR

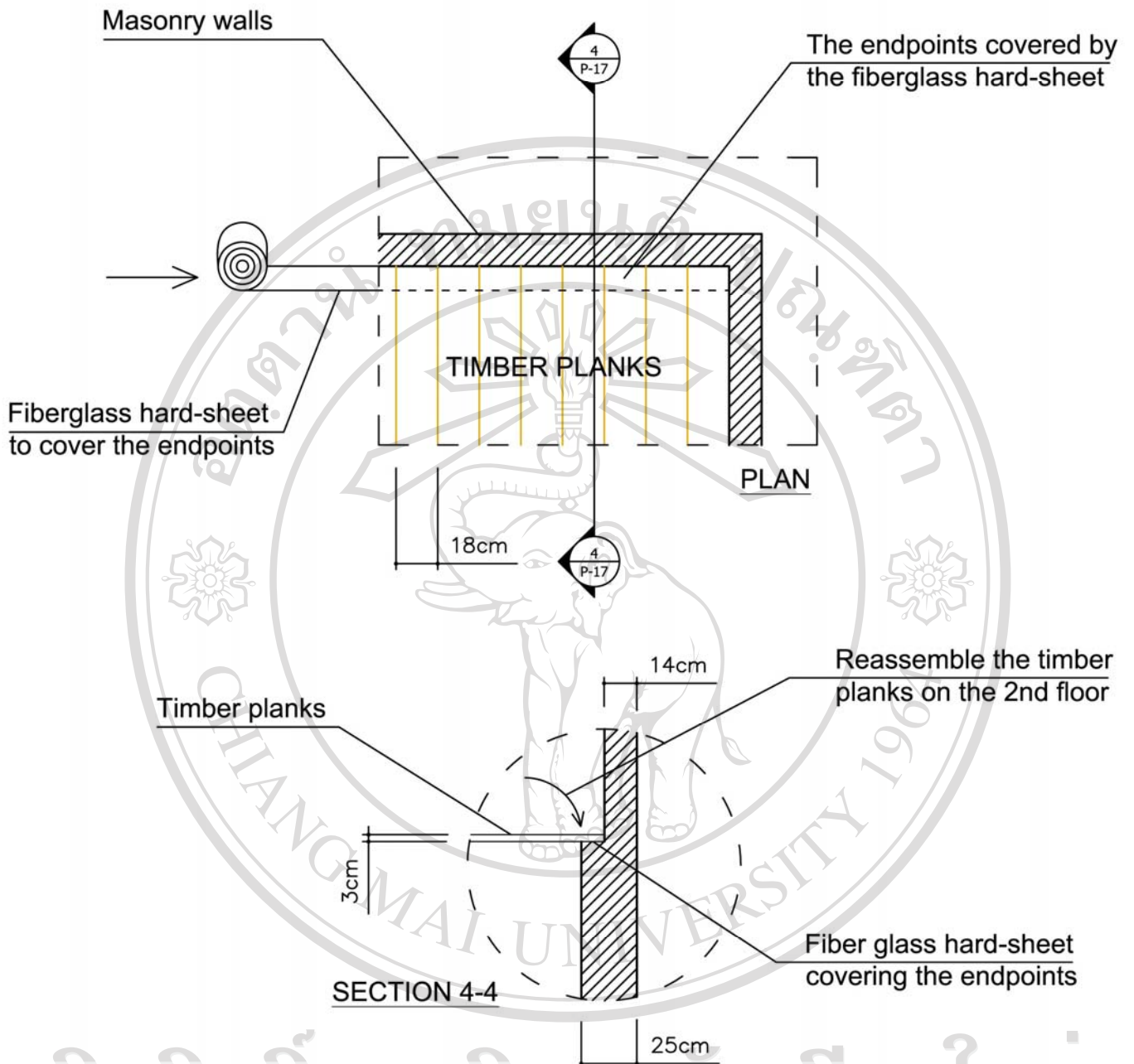

ลิขสิทธิ์มหาวิทยาลัยเชียงใหม่
 Copyright © by Chiang Mai University
 All rights reserved

T3 **STEP 4**
 Scale: 1:25

- Step 4:**
- + Use fiberglass hard-sheet (*tấm cứng vải thủy tinh*) to cover the endpoints contacting the masonry walls for moisture-resistance
 - + Reassemble the timber planks on the 2nd floor as beginning and finish

Project name and address THE TU GIAC HOUSING CONSERVATION PROTOTYPE HUE CITY, VIETNAM		Sheet No.
Name and address TRAN TUAN ANH FACULTY OF ARCHITECTURE, CHIANG MAI UNIVERSITY	Scale 1: 25	P-17.3
	Date Aug - 2008	

METHODS FOR THE DECAYED *Liet* TILES OF THE HIP ROOF

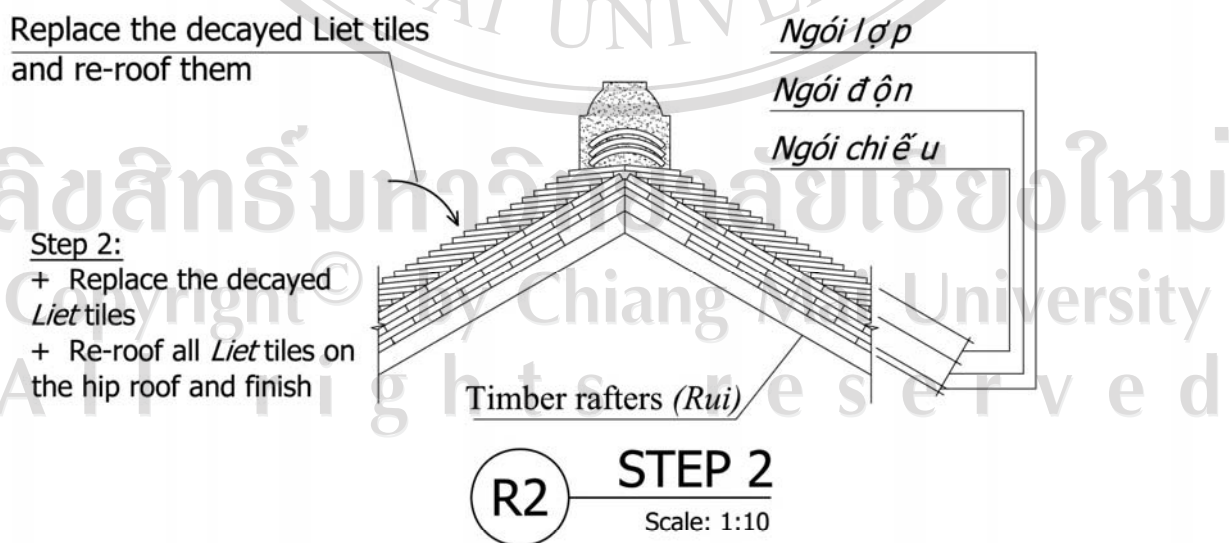
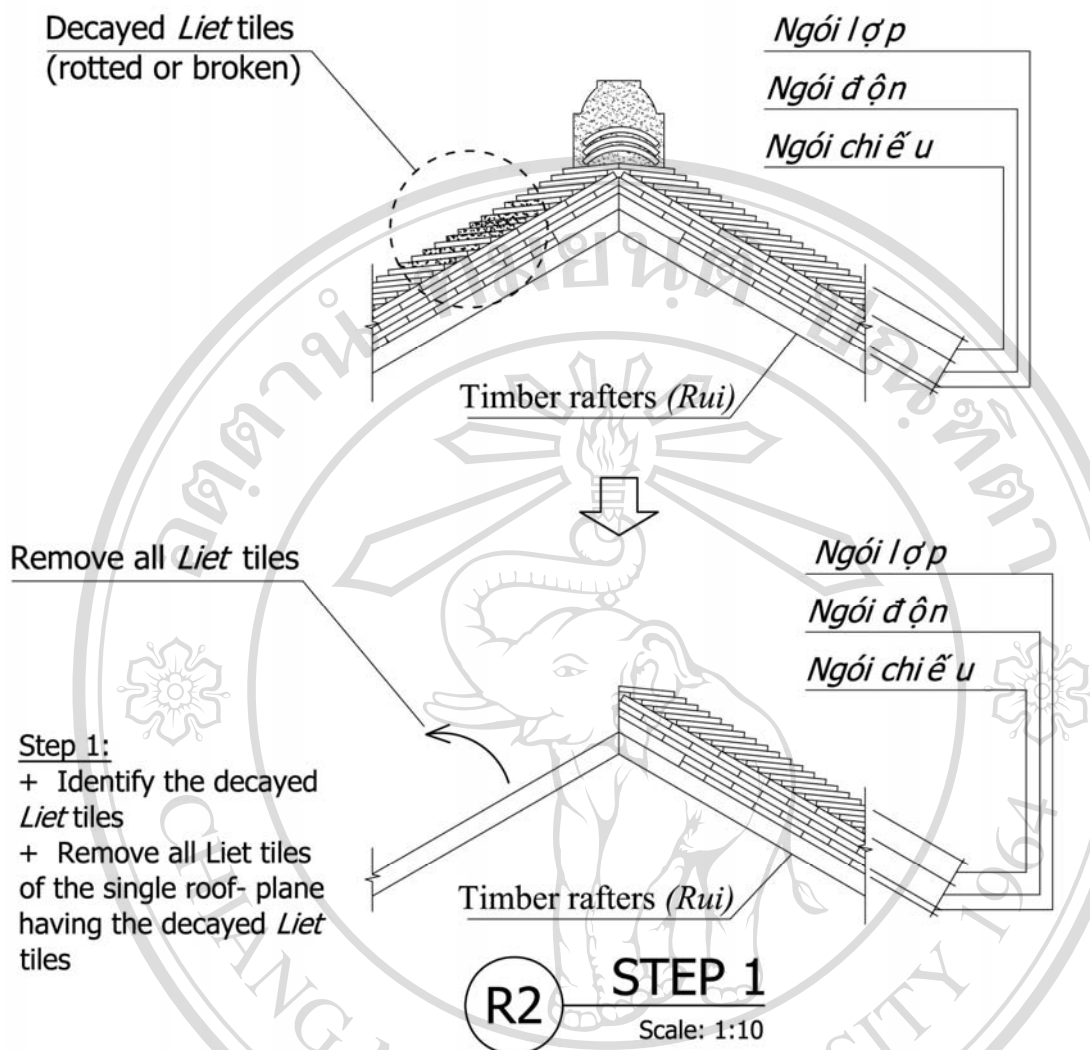

Project name and address THE TU GIAC HOUSING CONSERVATION PROTOTYPE HUE CITY, VIETNAM		Sheet No.
Name and address TRAN TUAN ANH FACULTY OF ARCHITECTURE, CHIANG MAI UNIVERSITY	Scale 1: 10	P-18
	Date Aug - 2008	

METHODS FOR THE DECAYED TIMBER ELEMENTS OF THE HIP ROOF

Decayed timber elements
(rafters, purlins, or trusses)

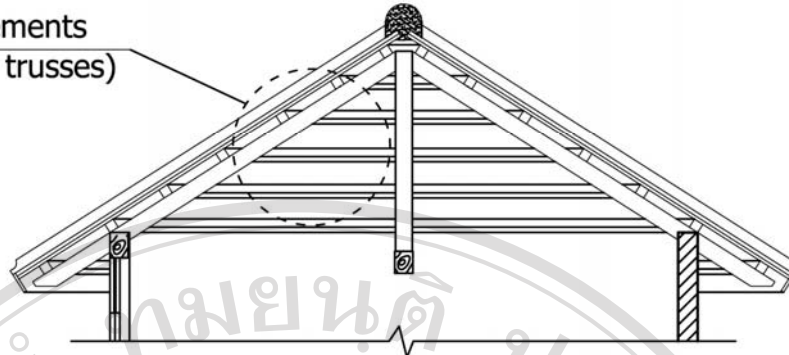

SECTION OF HIP ROOF

Scale: 1:50

Step 1:

- + Remove all Liet tiles of the hip roof
- + Remove the rafters, purlins, or trusses dependent on the location of decayed timber elements in rafters, purlins, or trusses
- + Mark the timber elements which are removed to avoid confusion

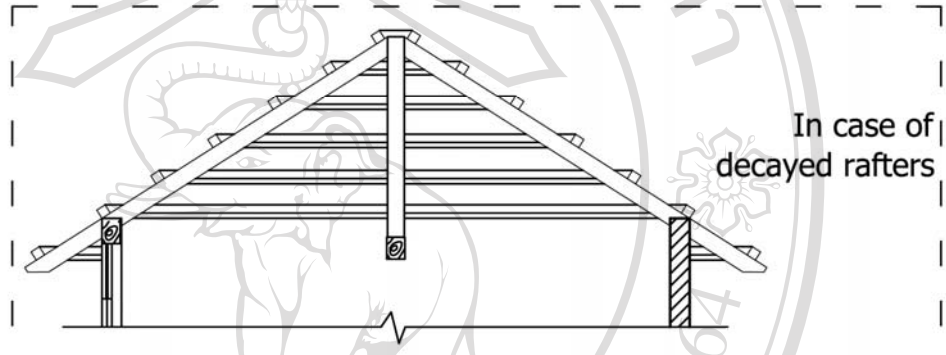

In case of decayed rafters

Step 2:

- + The serious decayed elements will be replaced by the same species of wood
- + The non-serious decayed elements (usually cracks) will be repaired according to the methods for the timber beams in:

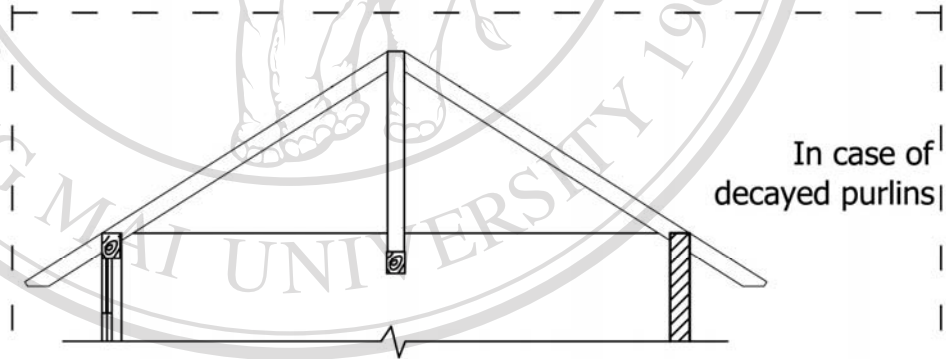
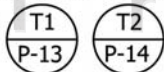

In case of decayed purlins

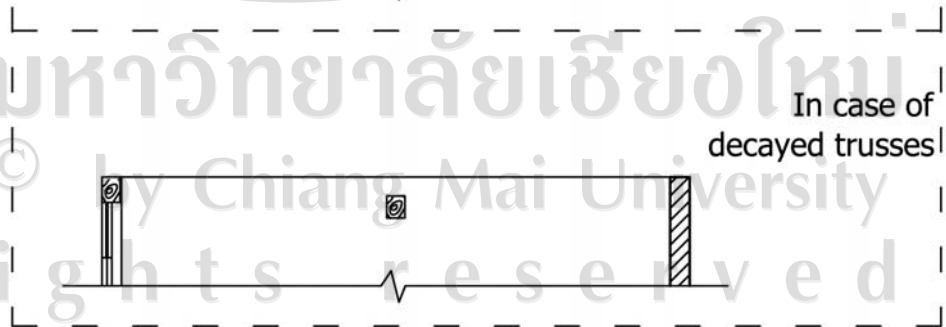

In case of decayed trusses



STEP 1

Scale: 1:50



STEP 2

Scale: 1:50

Project name and address THE TU GIAC HOUSING CONSERVATION PROTOTYPE HUE CITY, VIETNAM		Sheet No.
Name and address TRAN TUAN ANH FACULTY OF ARCHITECTURE, CHIANG MAI UNIVERSITY	Scale 1: 50	P-19.1
	Date Aug - 2008	

METHODS FOR THE DECAYED TIMBER ELEMENTS OF THE HIP ROOF

Step 3:

+ Before roofing *Liet* tiles, it is required to cover all the timber elements by moisture- and fungi-resistance paints

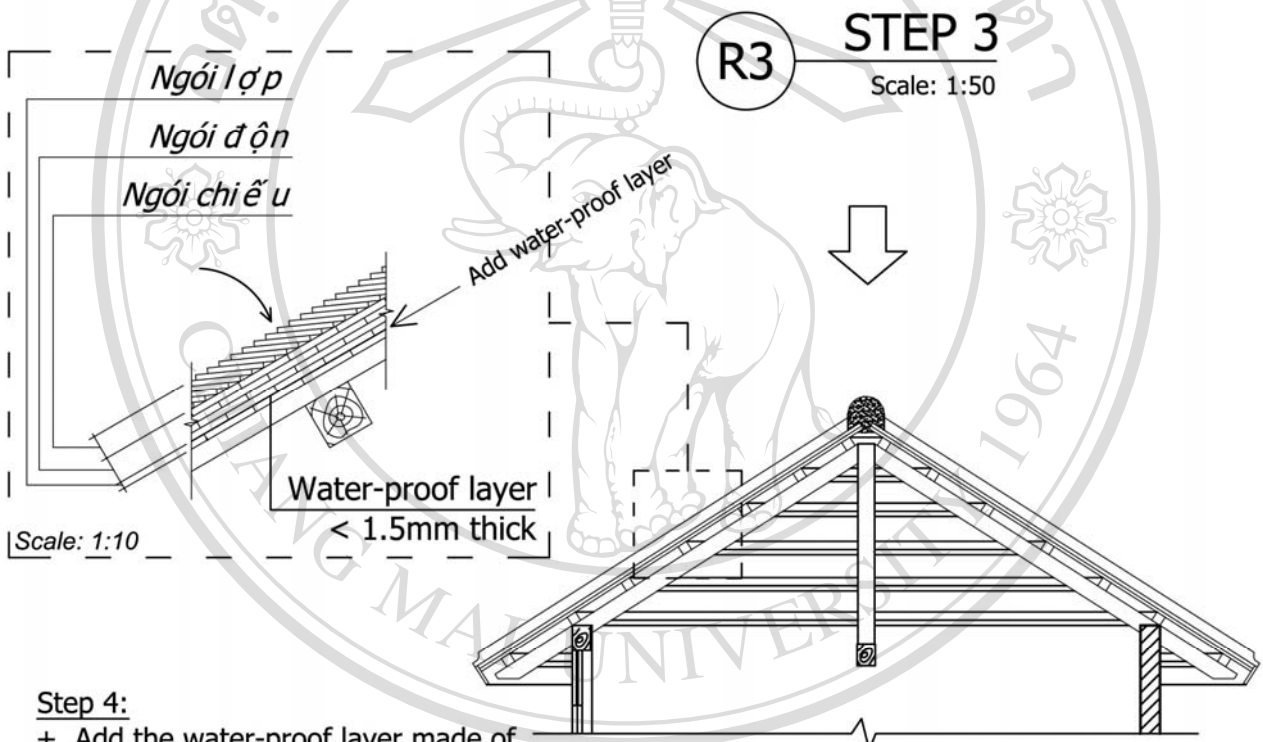
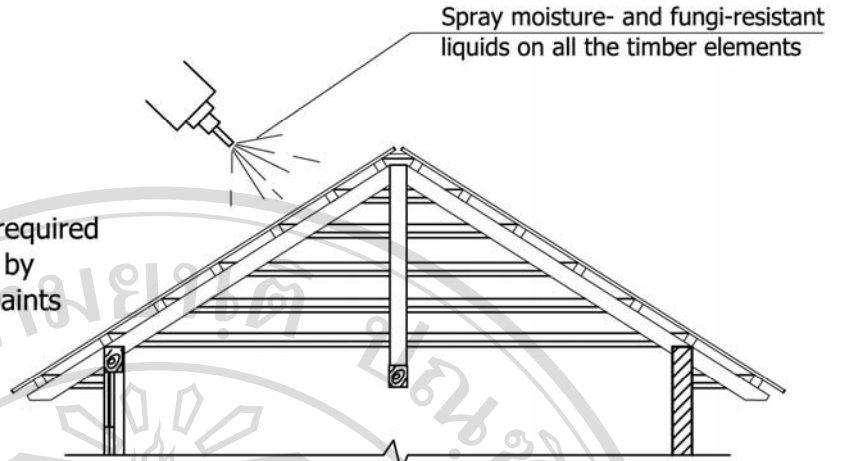

Step 4:

+ Add the water-proof layer made of Leaden, PVC, or Bitumen with the thickness < 1.5mm into the roof to prevent moisture-penetration down to timber elements underneath

+ This layer is put on the bottom layer of *Liet* tiles (*Ngói chi ế u*) and be fixed directly to the timber rafters by small steel nails

+ The heads of steel nails are covered by rust-resistant Polyurethane Glue

+ Roof the top layer of *Liet* tiles (*Ngói lợp*) and finish

SECTION OF HIP ROOF

Scale: 1:50

R3

STEP 4

Scale: 1:50

Project name and address THE TU GIAC HOUSING CONSERVATION PROTOTYPE HUE CITY, VIETNAM		Sheet No.
Name and address TRAN TUAN ANH FACULTY OF ARCHITECTURE, CHIANG MAI UNIVERSITY	Scale 1: 50, 1: 10	P-19.2
	Date Aug - 2008	

METHODS FOR THE ENTRANCE DOORS USING FILLED-IN HORIZONTAL WOODEN PANELS

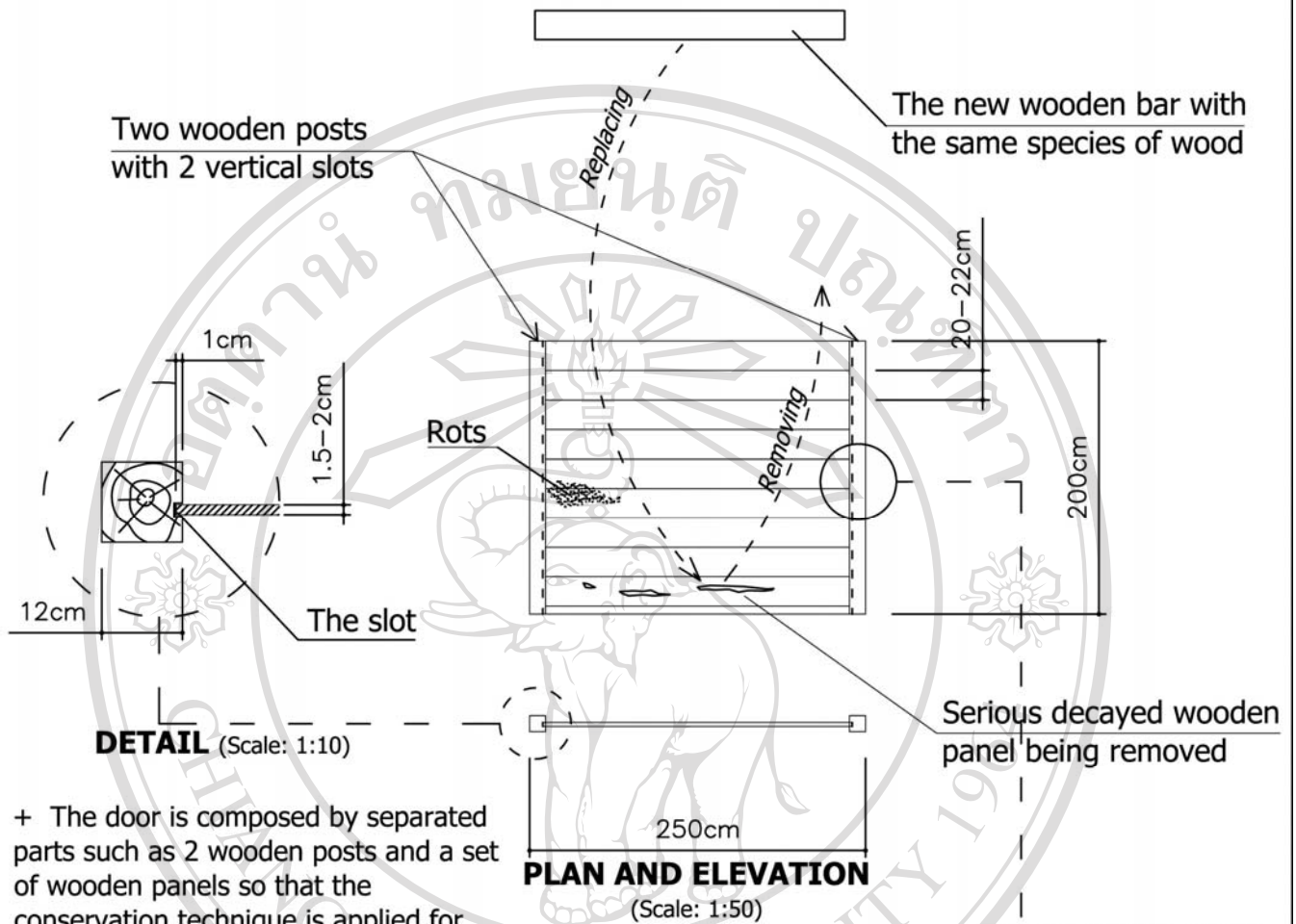

+ The door is composed by separated parts such as 2 wooden posts and a set of wooden panels so that the conservation technique is applied for each part dependent on the level of its decay.

+ **Step 1:** The serious decayed wooden parts: many rots and crack will be replaced by the new ones with the same species of wood as the old ones.

+ **Step 2:** The non-serious decayed parts (cracks < 5mm width or rots) are repaired:

+ cracks < 5mm width: T2
P-14

- + Rots:
- Take off all rots
 - Clean the wood surface
 - Cover by the decayed part by fungi-resistant paints

Panels filled in the slot

DETAIL (Scale: 1:20)

Cracks < 5mm width

T2
P-14

D

METHODS FOR DOOR

Scale: 1:50, 1:20, 1:10

Project name and address THE TU GIAC HOUSING CONSERVATION PROTOTYPE HUE CITY, VIETNAM		Sheet No.
Name and address TRAN TUAN ANH FACULTY OF ARCHITECTURE, CHIANG MAI UNIVERSITY	Scale 1: 50, 1: 20, 1: 10	P-20
Date Aug - 2008		

METHODS FOR THE SLAT SHUTTER WINDOWS

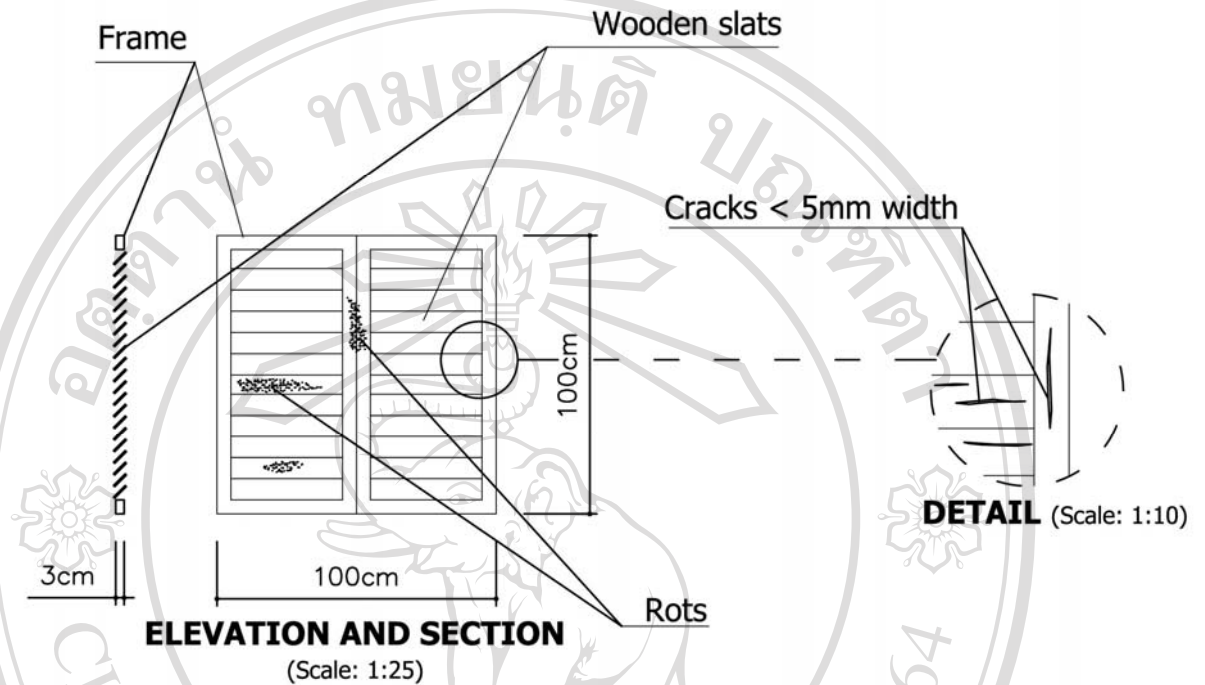

+ Similar to the door, the slat shutter window is created from separated wooden parts such as the slats and border frame. Thus the conservation technique applied for each part is dependent on the level of its decay. The main decay of the shutter window in *Tu Giac* houses is the rots and small cracks on the wood-surface.

+ Step 1: Cracks < 5mm width: **T2**
P-14

+ Step 2: Rots:
 - Take off all rots
 - Clean the wood surface
 - Cover by the decayed part by fungi-resistant paints

ลิขสิทธิ์มหาวิทยาลัยเชียงใหม่
 Copyright © Chiang Mai University
 All rights reserved

W METHODS FOR WINDOW

Scale: 1:25

Project name and address THE TU GIAC HOUSING CONSERVATION PROTOTYPE HUE CITY, VIETNAM		Sheet No.
Name and address TRAN TUAN ANH FACULTY OF ARCHITECTURE, CHIANG MAI UNIVERSITY	Scale 1: 25, 1: 10	P-21
	Date Aug - 2008	

METHODS FOR RESTORING THE FACADE OF THE TWO-STOREY BUILDINGS AFTER THE ADDITIONS BEING REMOVED

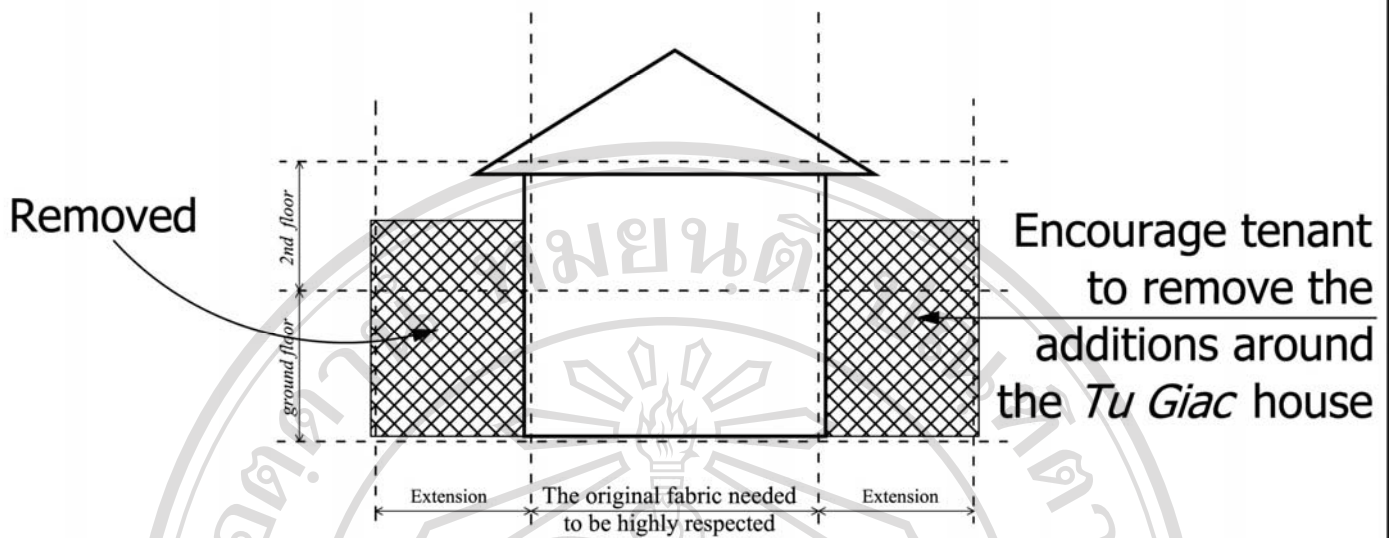

F1 Encouraging ADDITIONS being REMOVED from facade Scale: 1:50

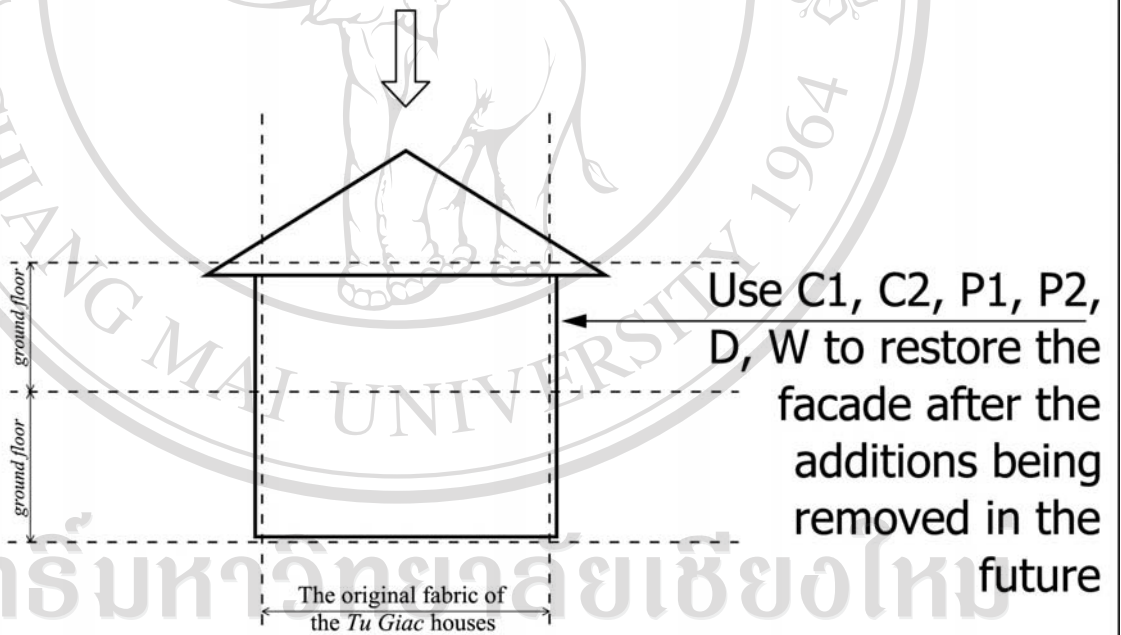

F2 FACADE RESTORATION after Additions being Removed Scale: 1:50

Notes:

The conservation aim is to protect the original 2-storey fabric of Tu Giac House. It is the remove of the latterly additional parts which have been affected the original fabrics of the two-storey *Tu Giac* houses

Project name and address THE TU GIAC HOUSING CONSERVATION PROTOTYPE HUE CITY, VIETNAM		Sheet No.
Name and address TRAN TUAN ANH FACULTY OF ARCHITECTURE, CHIANG MAI UNIVERSITY	Scale 1: 50	P-22
	Date Aug - 2008	

* In addition, the *Tu Giac* Housing Conservation Prototype provides the preventive method, named **DP**, to avoid and maintain all Architectural Elements of *Tu Giac* houses, given in Fig.4.3:

Fig.4.3 The method **DP** for the Prevention and Maintenance

Architectural Elements	Conservation Methods of Prevention
<p>Masonry works and <i>Vo</i> bricks: The Load Bearing Walls (A₁)</p> 	<ul style="list-style-type: none"> ▪ Three solutions for maintaining the mortar in the walls: <ol style="list-style-type: none"> 1. Clean wall-surfaces usually and keep them always dry 2. Cover the wall-surfaces by the Waterseal, the botanic-oil originated paint²⁷ 3. Take off the old and coating the new white-wash annually ▪ Solutions for maintaining the <i>Vo</i> bricks: Always keep the plaster outside in good condition by three solutions above for the maintenance of <i>Vo</i> bricks inside
<p>Wood works including: The High-Pitch Timber Stair (A₃) The Timber Floor on the 2nd level (A₄) The Timber Bars of the Hip Roofs (A₅) The Doors using filled-in Horizontal Wooden Panels & the Shutter Windows (A₆)</p>	<ul style="list-style-type: none"> ▪ The first and most important line to protect wood works from deterioration is to keep wood dry (below 15% moisture content).²⁸ ▪ Four steps for preventing fungal and pest attacks:²⁹ <ol style="list-style-type: none"> 1. Take off all existing rots caused by pest and fungi 2. Clean the wood surface 3. Spray the fungicide and pesticide: DH92 or Tetol with the required amount 0,15litre /m² 4. Sweep the epoxy-originated chemicals for maintenance with the required amount 0,5litre /m² ▪ Four solutions for maintaining timber elements and slowing down their aging process: <ol style="list-style-type: none"> 1. Clean the timber elements usually and keep them always dry 2. Use the Water-seal to cover the wood surface³⁰ 3. Use the dilute Vecni-Tampon liquid to cover wood surface 4. Intensify air-circulation and natural light inside the house by frequently opening windows and doors to reduce internal humidity (<i>the good condition for the growth of fungi and pests</i>)

²⁷ Institute of Science Technology Construction of Central Vietnam, 2002

²⁸ Joseph R. Loferski, 2001

²⁹ *Hue Heritage House*. Guidelines for Conserving Hue Traditional Houses. 2003

³⁰ Ibid

The Hip Roofs (A ₆)	<ul style="list-style-type: none"> ▪ Solutions for preventing water-absorption from the top: Use one cover-sheet which is made from PVC and be placed inside the roof within the thickness below 1mm³¹
---------------------------------	--

4.8 Conclusions of Chapter 4

The conservation method- itemized model (Fig.3.24) has been utilized to create the 'prototype' conservation methods and techniques in Chapter 4. A set of drawings (P-01 through P-22) is prepared with the typical building orientation addressed in Drawing P-01. Plans of Tu Giac House are shown between P-02 and P-03, front elevation P-04, side elevation P-05, rear elevation P-06, and section 1-1, 2-2 on P-08. The itemized decays and destructions are illustrated on P-03 through P-08.

Fig.4.2 illustrates 15 conservation techniques on masonry wall cracks (C1, C2), on plaster decays (P1, P2), on timber deterioration (T1, T2, T3), on roof tiles and roof ridge-structure cracks and deterioration (R1, R2, R3), on timber stairs (S1), on windows and doors repair (D, W), and on façade restoration after extensions attached to *Tu Giac* house are being removed in the future (F1, F2).

ลิขสิทธิ์มหาวิทยาลัยเชียงใหม่
Copyright© by Chiang Mai University
All rights reserved

³¹ Institute of Science Technology Construction of Central Vietnam, 2002