

Chapter IV

Factors associated and their relationship with the level of adoption of Rice Production Practices

Based on the land extent in which rice production practices are applied and continuity of adoption, level of adoption is computed for all three-Rice Production Practices (RPP); Land Preparation and Planting (LPP), Soil Improvement Methods (SIM) and Use of Agrochemicals (UAC) (see section 3.5). LPP and UAC have more or less similar kind of pattern on adoption level with 48% and 40% non-adopters and 29% and 31% adopters respectively. SIM has comparatively lower percentage of adopters (17%) and higher percentage of non-adopters (57%). The percentages of partial adopters are 22, 26 and 29 in LPP, SIM and UAC respectively (Figure 4.1).

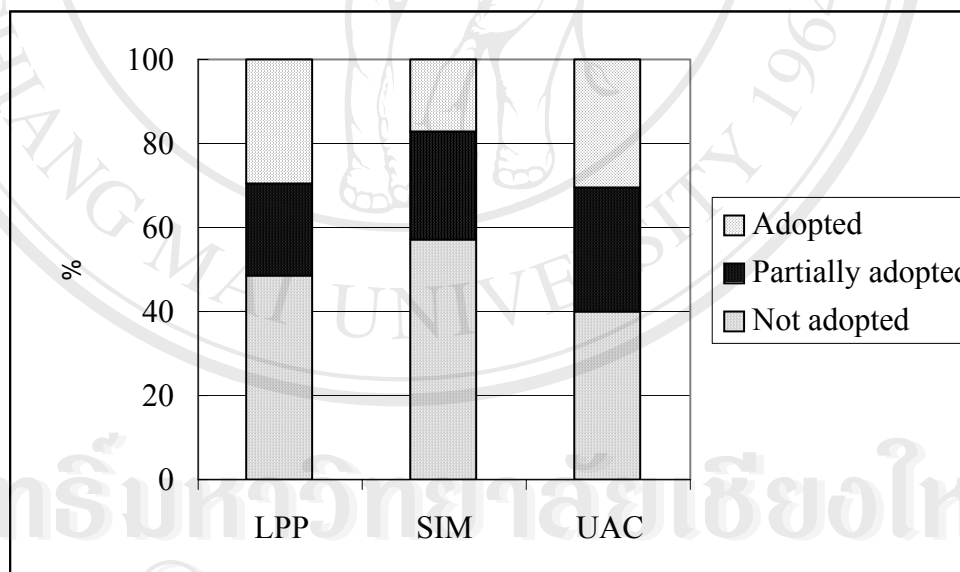

Figure 4.1: Percentage of adoption levels for three-rice production practices.
Source: Field survey, 2004.

Cross tabulation was performed to measure the association of different social, economic and institutional variables with adoption level for each Rice Production Practice (RPP). The definitions, labels and codes of predictor variables are summarized in Table 3.2. The results of two way cross tabulation of each predictor

variable for three Rice Production Practices are summarized in single table format, so as to easily compare the relationships among 3 production practices. Altogether seventeen possible predictors are taken into consideration to make two-way tables with three adoption categories. The chi-square tests were done to examine the relationship of adoption levels and categories of predictor variables for each RPP separately and those results are displayed following each summarized two-way table. The particulars of variables are displayed in Table 3.2. Relevant statistical procedures are explained in the sub section 3.8.1.

4.1. Social Factors

Age of the household head, Education level of the household, Family labor availability for agricultural purposes, Number of family members involved in agricultural decision making and Social Participation of the household head are the social factors interested in the study.

4.1.1. Age of the Household Head

Within the sample about 78% farm household heads are between 41 and 60 years of age. There are only 6% of farmers over 60 years of age and only 16% farmers are below 40 years of age (Figure 4.2).

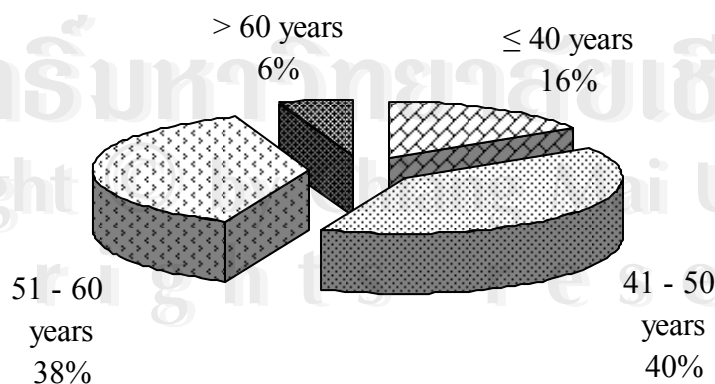

Figure 4.2: Percentage distribution of age categories.
Source: Field survey, 2004.

There are only 10 farmers over 60 years of age in the sample and interestingly 9 of them are non-adopters and the other one is a partial adopter with regard to LPP and SIM practices. However the two-sided asymptotic significance values of the chi-square statistics are greater than 0.05 for LPP and SIM. Hence we can conclude that there are no relationships between age and adoption levels of these two production practices (Table 4.1).

Table 4.1: Two way cross tabulation of Farmer Age and Adoption Level for 3 Rice Production Practices (RPP).

Level of Adoption	Land Preparation and Planting (LPP)					Soil Improvement Methods (SIM)					Use of Agro Chemicals (UAC)				
	Age Category					Age Category					Age Category				
	40	41-50	51-60	60	Total	40	41-50	51-60	60	Total	40	41-50	51-60	60	Total
Not adopted	12	33	33	9	87	14	42	38	9	103	8	26	29	9	72
% within RPP	14	38	38	10	100	14	41	37	9	100	11	36	40	13	100
% within age	41	45	49	90		48	58	56	90		28	36	43	90	
Partially adopted	5	19	15	1	40	7	18	20	1	46	7	26	20	0	53
% within RPP	13	48	38	3	100	15	39	43	2	100	13	49	38	0	100
% within age	17	26	22	10		24	25	29	10		24	36	29	0	
Adopted	12	21	20	0	53	8	13	10	0	31	14	21	19	1	55
% within RPP	23	40	38	0	100	26	42	32	0	100	25	38	35	2	100
% within age	41	29	29	0		28	18	15	0		48	29	28	10	
Total	29	73	68	10	180	29	73	68	10	180	29	73	68	10	180

Source: Field survey, 2004.

But in UAC, the two-sided asymptotic significance value of the chi-square statistic is 0.011; we can conclude that there are differences among age categories with respect to different adoption levels of UAC (Table 4.2). In UAC production practice, in over 60-year age group, 90% of farmers are non-adopters and there are only 10% adopters. Between 40 to 60 years of age there is not much difference can be

observed among three adoption categories. Below 40 years age group has 48% adopters, 24% partial adopters and 28% non-adopters.

Table 4.2: Chi-Square Tests for Farmer Age and Adoption Level for 3 Rice Production Practices.

	LPP	SIM	UAC
Pearson Chi-Square value	9.86	7.49	16.59
df	6	6	6
Asymp. Sig. (2-sided)	0.131	0.278	0.011

4.1.2. Education Level of the Household Head

Twenty seven percent household heads have grade 5 or below education. Only 14% farmers have grade 10 or higher education level. 59% of household heads have grade 6 to grade 10-education level (Figure 4.3).

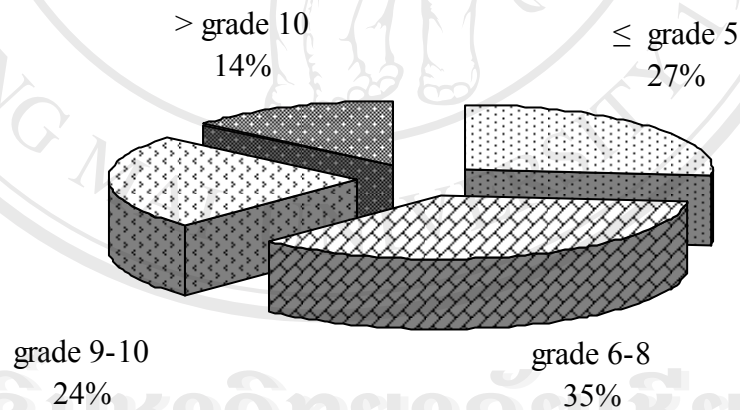

Figure 4.3: Percentage distribution of education categories.

Source: Field survey, 2004.

In LPP, education category ≤ 5 has 63% non-adopters and 23% adopters while education category >10 has only 8% non adopters and 56% adopters (Table 4.3). About 87% of non-adopters has grade 8 or below education and only 12% has beyond grade 9 education while 46% of adopters has grade 8 or below education and 54% has beyond grade 9 education.

In Soil Improvement Methods, 95% has grade 8 or below education and only 5% has beyond grade 9 education while 3% of adopters has grade 8 or below education and 97% has beyond grade 9 education. Also education category ≤ 5 has 92% non-adopters, 8% partial adopters and 0% adopters while education category >10 has 0% non adopters, 20 partial adopters and 80% adopters.

Table 4.3: Two way cross tabulation of Education and Adoption Level for 3 Rice Production Practices (RPP).

Level of Adoption	Land Preparation and Planting (LPP)					Soil Improvement Methods (SIM)					Use of Agro Chemicals (UAC)				
	Education Category					Education Category					Education Category				
	≤ 5	6-8	9-10	>10	Total	≤ 5	6-8	9-10	>10	Total	≤ 5	6-8	9-10	>10	Total
Not adopted	30	46	9	2	87	44	54	5	0	103	30	35	5	2	72
% within RPP	34	53	10	2	100	43	52	5	0	100	42	49	7	3	100
% within education	63	72	21	8		92	84	12	0		63	55	12	8	
Partially adopted	7	5	19	9	40	4	9	28	5	46	7	18	18	10	53
% within RPP	18	13	48	23	100	9	20	61	11	100	13	34	34	19	100
% within education	15	8	44	36		8	14	65	20		15	28	42	40	
Adopted	11	13	15	14	53	0	1	10	20	31	11	11	20	13	55
% within RPP	21	25	28	26	100	0	3	32	65	100	20	20	36	24	100
% within education	23	20	35	56		0	2	23	80		23	17	47	52	
Total	48	64	43	25	180	48	64	43	25	180	48	64	43	25	180

Source: Field survey, 2004.

The UAC production practice has more or less similar trend as LPP. Education category <5 has 63% non-adopters and 23% adopters while >10 education category has only 8% non-adopters and 52% adopters. 90% of non-adopters has grade 8 or below education level and only 10% has beyond grade 9 education while 60% of adopters has grade 9 or higher education level.

The two sided asymptotic significance values of the chi-square statistics are smaller than 0.001 and this implies that different categories of education associate with different adoption levels for all three-production practices (Table 4.4).

Table 4.4: Chi-Square Tests for Education and Adoption Level for 3 Rice Production Practices.

	LPP	SIM	UAC
Pearson Chi-Square value	52.06	159.14	43.42
df	6	6	6
Asymp. Sig. (2-sided)	< .001	< .001	< .001

4.1.3. Family Labor Availability for Agricultural Activities

We can assume that larger family size generally associated with a greater labor force available to the household for operation of production practices and therefore this can be considered as a proxy to family size of the farmer. In the sample 40% households have less than or equal to 1.5 labor units available for agricultural activities. 38% households have more than 1.5 to 3 labor units available for agricultural activities. 22% households have more than 3 labor units available for agricultural activities (Figure 4.4).

No distinguish relationship among family labor categories and adoption categories can be observed in Table 4.5. Two-sided asymptotic significance values of the chi-square statistics are greater than 0.05 for all three categories on family labor. Hence there are no differences among family labor categories with respect to different adoption intensities of all three rice production practices (Table 4.6). Though most of the rice production practices are highly labor intensive, this results show that there is no relationship between adoption level of rice production practices and number of household members engaged in agriculture.

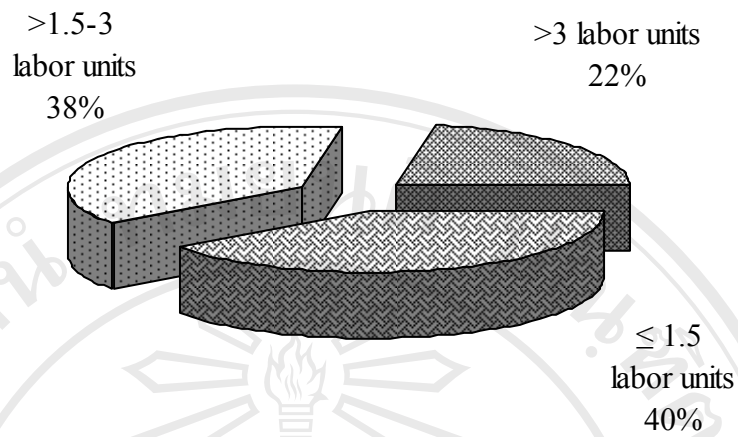

Figure 4.4: Percentage distribution of family labor categories.
Source: Field survey, 2004.

Table 4.5: Two way cross tabulation of Family Labor and Adoption Level for 3 Rice Production Practices (RPP).

Intensity of Adoption	Land Preparation and Planting (LPP)				Soil improvement methods (SIM)				Use of agro chemicals (UAC)			
	Family labor				Family labor				Family labor			
	≤ 1.5	>1.5-3	> 3	Total	≤ 1.5	>1.5-3	> 3	Total	≤ 1.5	>1.5-3	> 3	Total
Not adopted	39	28	20	87	41	40	22	103	32	24	16	72
% within RPP	44	32	23	100	39	38	21	100	44	33	22	100
% within labor	54	41	50		56	58	55		44	35	40	
Partially adopted	14	15	11	40	24	12	10	46	23	19	11	53
% within RPP	35	37	27	100	52	26	21	100	43	35	20	100
% within labor	19	22	27		33	17	25		31	27	27	
Adopted	19	25	9	53	7	16	8	31	17	25	13	55
% within RPP	35	47	17	100	22	51	25	100	30	45	23	100
% within labor	26	36	22		10	23	20		23	36	30	
Total	72	68	40	180	72	68	40	180	72	68	40	180

Source: Field survey, 2004.

Table 4.6: Chi-Square Tests for Family Labor and Adoption Level for 3 Rice Production Practices.

	LPP	SIM	UAC
Pearson Chi-Square value	4.12	7.54	3.03
df	4	4	4
Asymp. Sig. (2-sided)	0.389	0.109	0.552

4.1.4. Family Member Involvement in Agricultural Decision Making

Approximately in half of the sample households (51%), agricultural decision-making is done only by household heads and in other half of households other family members also involved in decision-making (Figure 4.5).

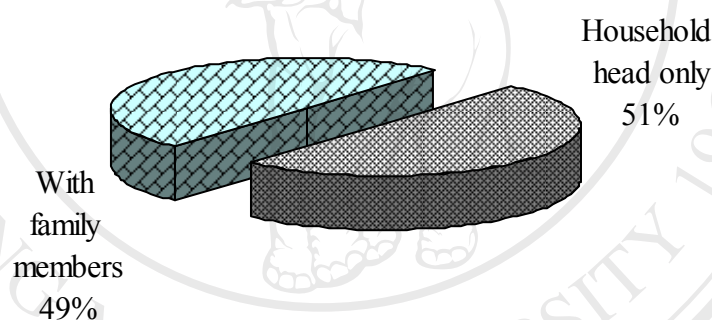

Figure 4.5: Percentage distribution of family member involvement in agricultural decision-making.

Source: Field survey, 2004.

In LPP practice, 64% non-adopters take agricultural decisions only by household head and only in 36% households other members are involved in agricultural decision making. In partial adopter and adopter categories, in 65% and 60% households, other members involved in agricultural decision making while only 35% and 40% take decisions by household head alone. There are only 62% non-adopters and 23% adopters in the households in which agricultural decisions are taken only by household heads. But in the group in which other family members other than

household head are involved in decision-making, there are 36% adopters and only 35% non-adopters (Table 4.7).

Under SIM, 59% households take decisions by household head alone and in 41% households, other members are involved in decision making in non-adopter category. In adopter category, household heads take agricultural decisions alone in 42% cases, while in 58% cases, other family members involved in agricultural decision-making.

Other members take part in agriculture decisions in 69% households within adopted group in UAC practice while in 31% households, agricultural decisions taken by household head alone. In non adopted category, in two third of households, agricultural decisions are taken only by household head and only in one third of households, other members are also involved in decision making.

Table 4.7: Two way cross tabulation of Agricultural Decision Making and Adoption Level for 3 Rice Production Practices (RPP).

Intensity of Adoption	Land Preparation and Planting (LPP)			Soil Improvement Methods (SIM)			Use of Agro Chemicals (UAC)		
	Agricultural decision making			Agricultural decision making			Agricultural decision making		
	≤ 1	> 1	Total	≤ 1	> 1	Total	≤ 1	> 1	Total
Not adopted	56	31	87	61	42	103	48	24	72
% within RPP	64	36	100	59	41	100	67	33	100
% within decision	62	35		67	47		53	27	
Partially adopted	14	26	40	17	29	46	26	27	53
% within RPP	35	65	100	37	63	100	49	51	100
% within decision	15	29		19	33		29	30	
Adopted	21	32	53	13	18	31	17	38	55
% within RPP	40	60	100	42	58	100	31	69	100
% within decision	23	36		14	20		19	43	
Total	91	89	180	91	89	180	91	89	180

Source: Field survey, 2004.

All three Chi square values are smaller than 0.05 significant level (Table 4.8). Therefore households in which other members other than household head involved in agricultural decision-making have different level of adoption than households in which household head take decision alone in all three rice production practices.

Table 4.8: Chi-Square Tests for Agricultural Decision Making and Adoption Level for 3 Rice Production Practices.

	LPP	SIM	UAC
Pearson Chi-Square value	13.05	7.42	16.02
df	2	2	2
Asymp. Sig. (2-sided)	0.001	0.024	<0.001

4.1.5. Social Participation of the Household Head

It is assumed that number of social organizations involved by the household heads is a measure of active social participation. Over 90% of farmers are involved in at least one social organization and only 16 (9%) farmers are not involved in such organizations. 48% household heads are involved in two social organizations (Figure 4.6).

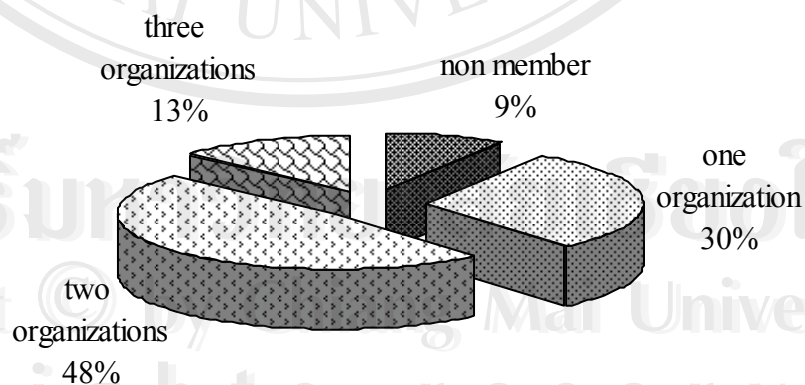

Figure 4.6: Percentage distribution of number of social organizations involved by the household head.

Source: Field survey, 2004.

All the adopters are involved at least in one social organization in all three rice production practices. LPP and UAC show more or less similar relationship among adoption categories and number of social organizations involved. All the household heads whom are not involved in any social organization, are non-adopters in those two rice production practices (Table 4.9). In LPP, all the household heads whom are involved in three social organizations are either partial adopters or adopters.

There are 88% non-adopters and 12% partial adopters in the households where household heads are not involved in any social organization under SIM practice. Interestingly farmers involved in two social organizations have highest percentage of adopters (29%). Farmers involved in three social organizations have 63% non-adopters and only 4% adopters.

Table 4.9: Two way cross tabulation of Number of Social Organizations involved and Adoption Level for 3 Rice Production Practices (RPP).

Intensity of Adoption	Land Preparation and Planting (LPP)					Soil Improvement Methods (SIM)					Use of Agro Chemicals (UAC)				
	Number of Social Organizations					Number of Social Organizations					Number of Social Organizations				
	0	1	2	3	Total	0	1	2	3	Total	0	1	2	3	Total
Not adopted	16	36	35	0	87	14	31	43	15	103	16	26	29	1	72
%within RPP	18	41	40	0	100	14	30	42	15	100	22	36	40	1	100
%within number	100	67	41	0		88	57	50	63		100	48	34	4	
Partially adopted	0	6	24	10	40	2	18	18	8	46	0	17	30	6	53
%within RPP	0	15	60	25	100	4	39	39	17	100	0	32	57	11	100
%within number	0	11	28	42		12	33	21	33		0	31	35	25	
Adopted	0	12	27	14	53	0	5	25	1	31	0	11	27	17	55
%within RPP	0	23	51	26	100	0	16	81	3	100	0	20	49	31	100
%within number	0	22	31	58		0	9	29	4		0	20	31	71	
Total	16	54	86	24	180	16	54	86	24	180	16	54	86	24	180

Source: Field survey, 2004.

The two sided asymptotic significance values of the chi-square statistics are smaller than 0.001 and this implies that different level of social participation by the household heads associate with different adoption levels for all three-rice production practices (Table 4.10).

Table 4.10: Chi-Square Tests for Number of Social Organizations involved and Adoption Level for 3 Rice Production Practices.

	LPP	SIM	UAC
Pearson Chi-Square value	49.7003	21.226	49.145
df	6	6	6
Asymp. Sig. (2-sided)	<0.001	0.002	<0.001

4.2. Economic Factors

Extent of lowland area cultivated by household and tenure status of lowland are the economic factors considered. Since the household's wealth and income seem to be inconsistent those were excluded from the analysis.

4.2.1. Extent of Lowland cultivated by Household

Fifty one percent of households cultivate less than or equal to 1 ha of paddy land, 26% households cultivate more than 1 to 2 ha and 23% households cultivate more than 2 ha of paddy (Figure 4.7).

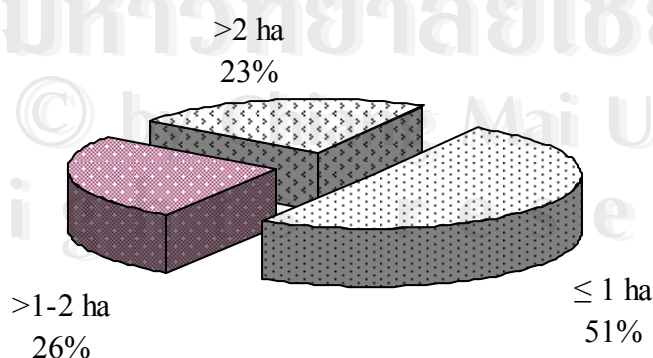

Figure 4.7: Percentage distribution of extent of lowland cultivated by households. Source: Field survey, 2004.

In LPP practice, 63% non adopters and 53% adopters have less than or equal 1 ha while 10% non adopters and 15% adopters have more than 2 ha respectively. But only 20% partial adopters have less than or equal 1 ha of lowland and 63% partial adopters has more than 2 ha of lowland. Within the households who have less than or equal 1 ha, there are 60% non adopters, 9% partial adopters and 31% adopters while in more than 2 ha category, there are 21% non adopters, 60% partial adopters and 29% adopters (Table 4.11). Majority of households in more than 2 ha category has mixed land ownerships, so this results can be further explained in the following section.

Table 4.11: Two way cross tabulation of Lowland Area cultivated by household and Adoption Level for 3 Rice Production Practices (RPP).

Intensity of Adoption	Land Preparation and Planting (LPP)				Soil improvement methods (SIM)				Use of agro chemicals (UAC)			
	Lowland Area (ha)				Lowland Area (ha)				Lowland Area (ha)			
	1	1-2	2	Total	1	1-2	2	Total	1	1-2	2	Total
Not adopted	55	23	9	87	57	31	15	103	40	24	8	72
% within RPP	63	26	10	100	55	30	15	100	56	33	11	100
% within area	60	49	21		63	66	36		44	51	19	
Partially adopted	8	7	25	40	21	11	14	46	29	5	19	53
% within RPP	20	18	63	100	46	24	30	100	55	9	36	100
% within area	9	15	60		23	23	33		32	11	45	
Adopted	28	17	8	53	13	5	13	31	22	18	15	55
% within RPP	53	32	15	100	42	16	42	100	40	33	27	100
% within area	31	36	19		14	11	31		24	38	36	
Total	91	47	42	180	91	47	42	180	91	47	42	180

Source: Field survey, 2004.

More or less similar tendency can be observed in Soil Improvement Methods. Non-adopters cultivate higher percentage of smaller lowland extents compared to the

adopters. Smaller and medium extent cultivators have higher percentage of non-adopters while larger extent cultivators have equal distribution of adoption intensities.

Under UAC also, non-adopters cultivate lower percentage of higher extents compared to the adopters. Since the two-sided asymptotic significance values of the chi-square statistic are smaller than 0.05 for all three-rice production practices, we can conclude that there are differences among lowland extent groups with respect to different adoption intensities (Table 4.12).

Table 4.12: Chi-Square Tests for Lowland Area cultivated by household and Adoption Level for 3 Rice Production Practices.

	LPP	SIM	UAC
Pearson Chi-Square value	46.19	12.02	18.29
df	4	4	4
Asymp. Sig. (2-sided)	<0.001	0.017	0.001

4.2.2. Tenure Status of Lowland

Out of 180 households, the great majority (90%) are lowland owners and only 3% are not owners and 7% are part owners (Figure 4.8). The households which owned a block of land and also leased in another block of land are considered as part owners.

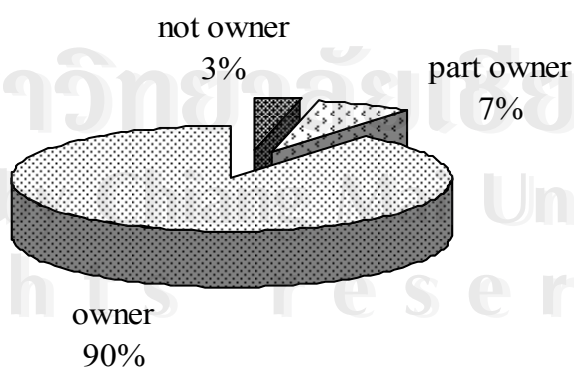

Figure 4.8: Percentage distribution of lowland tenure status among households.
Source: Field survey, 2004.

All *not owners*, 77% *part owners* and 44% *owners* are non-adopters in LPP practice. Adopted category has 32% *owners*, 15% *part owners* and 0% *not owners*. Non-adopted category has 7% *not owners*, 11% *part owners* and 82% *owners*. Within partial adopted category, there are 98% *owners* and 2% *part owners*. Adopted category has 96% *owners* and 4% *part owners* (Table 4.13).

In SIM practice, all the adopters and 98% partial adopters are in *owner* and *part owner* categories respectively. 83% non-adopters are also *owners* while there are only 5% *not owners* and 13% *part owners* in not adopted category.

Table 4.13: Two way cross tabulation of Lowland Tenurership and Adoption Level for 3 Rice Production Practices (RPP).

Intensity of Adoption	Land Preparation and Planting (LPP)					Soil improvement methods (SIM)					Use of agro chemicals (UAC)				
	Lowland Tenurership					Lowland Tenurership					Lowland Tenurership				
	not owner	part owner	owner	Total	not owner	part owner	owner	Total	not owner	part owner	owner	Total			
Not adopted	6	10	71	87	5	13	85	103	6	10	56	72			
% within RPP	7	11	82	100	5	13	83	100	8	14	78	100			
% within tenureship	100	77	44		83	100	53		100	77	35				
Partially adopted	0	1	39	40	1	0	45	46	0	3	50	53			
% within RPP	0	2	98	100	2	0	98	100	0	6	94	100			
% within tenureship	0	8	24		17	0	28		0	23	31				
Adopted	0	2	51	53	0	0	31	31	0	0	55	55			
% within RPP	0	4	96	100	0	0	100	100	0	0	100	100			
% within tenureship	0	15	32		0	0	19		0	0	34				
Total	6	13	161	180	6	13	161	180	6	13	161	180			

Source: Field survey, 2004.

All the adopters, 94% partial adopters and 78% non-adopters are *land owners*. All the *not owners*, 77% *part owners* and 35% *owners* are non-adopters. All three

intensities of adoption are equally distributed within *owner* category, but there are no adopters in *part owner* category.

Significance values of the chi-square statistics are smaller than 0.05 for all three rice production practices with regard to lowland tenureship. Hence we can conclude that there are differences among lowland tenureship categories and adoption intensities for all three rice production practices (Table 4.14).

Table 4.14: Chi-Square Tests for Lowland Tenureship and Adoption Level for 3 Rice Production Practices.

	LPP	SIM	UAC
Pearson Chi-Square value	11.88	12.95	19.50
df	4	4	4
Asymp. Sig. (2-sided)	0.018	0.012	0.001

4.3. Institutional Factors

Distance to Paddy Field from home, Distance to Extension Office from home, Easiness to irrigate, Number of trainings attended by household head, Number of field demonstrations attended by household head, Number of Extension Office Visits by household head, Number of Farm Visits by Extension Officers, Frequency of listening agriculture radio programs, Frequency of reading agriculture articles in newspapers and Frequency of viewing agriculture TV programs are the institutional factors interested.

4.3.1. Distance to Paddy Field from Home

About 47% of households are within 1 km proximity to their main rice field and 53% paddy fields are more than 1 km away from the farmer residences (Figure 4.9).

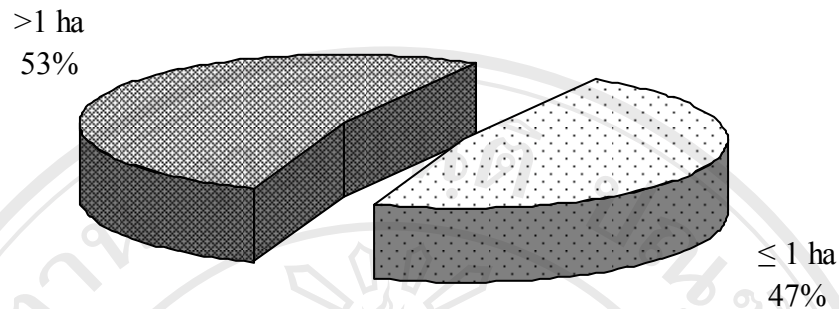

Figure 4.9: Percentage distribution of distance to paddy field from home.
Source: Field survey, 2004.

In Land Preparation and Planting practice, 71% non-adopters are reside more than one km away from the paddy field and 28% are in close proximity. 62% on adopters reside in close proximity while only 37% reside more than one km away from the main paddy field. Within the households who have residence more than one km away from paddy field, there are 65% non-adopters, 13% partial adopters and 21% adopters (Table 4.15).

In SIM, there is no remarkable variation among adoption categories as in other two production practices and distance categories. Within the UAC practice, in non-adopted category, 73% households are more than 1 km away from paddy field and 26% are in closer proximity. In adopted category, 72% are residing in close proximity and only 27% are residing away more than 1 km from paddy field. In close proximity category, there are 47% adopters, 30% partial adopters and 22% non-adopters. In far proximity group, 55% are non-adopters, 28% are partial adopters and only 15% are adopters.

The two sided asymptotic significance values of the chi-square statistics are smaller than 0.001 for all three RPPs. That means different proximity categories have different intensities of adoption in all three RPPs (Table 4.16).

Table 4.15: Two way cross tabulation of Distance to paddy field and Adoption Level for 3 Rice Production Practices (RPP).

Intensity of Adoption	Land Preparation and Planting (LPP)			Soil improvement methods (SIM)			Use of agro chemicals (UAC)		
	Distance to paddy field (km)			Distance to paddy field (km)			Distance to paddy field (km)		
	≤ 1	> 1	Total	≤ 1	> 1	Total	≤ 1	> 1	Total
Not adopted	25	62	87	51	52	103	19	53	72
% within RPP	28	71	100	49	50	100	26	73	100
% within distance	29	65		60	54		22	55	
Partially adopted	27	13	40	17	29	46	26	27	53
% within RPP	67	32	100	37	63	100	49	50	100
% within distance	31	13		20	30		30	28	
Adopted	33	20	53	17	14	31	40	15	55
% within RPP	62	37	100	54	45	100	72	27	100
% within distance	38	21		20	14		47	15	30
Total	85	95	180	85	95	180	85	95	180

Source: Field survey, 2004.

Table 4.16: Chi-Square Tests for Distance to paddy field and Adoption Level for 3 Rice Production Practices.

	LPP	SIM	UAC
Pearson Chi-Square value	23.34	2.88	26.97
df	2	2	2
Asymp. Sig. (2-sided)	< .001	0.041	< .001

4.3.2. Distance to Extension Office from Home

About 53% farmers are dwelling within 3 km distance from the relevant agriculture extension office, 42% farmers are in less than 3 to 6 km and only 10% households are in more than 6 km away from extension office (Figure 4.10).

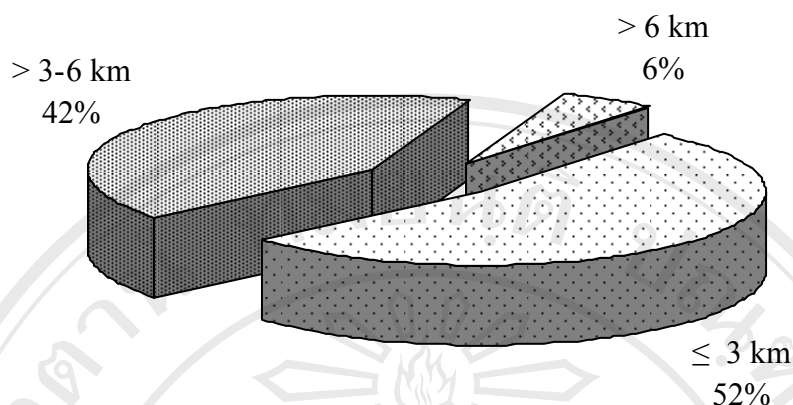

Figure 4.10: Percentage distribution of distance to extension office from home.
Source: Field survey, 2004.

In LPP, within adopted category, 72% households are in less than 3 km range, 28% are within 3 to 6 km range and there is no farmer in more than 6 km distance. In partial adopted category, 75% farmers reside within 3 km range from extension office and only 25% are in farer distances. In non-adopted category, only 31% households live in closer proximity and 69% are live more than 3 km away from extension office. There are no adopters in more than 6 km distance and 80% are non-adopters in that distance category. In less than 3 km category, there are 40% adopters, 32% partial adopters and 28% non-adopters (Table 4.17).

In SIM, there are 58% non-adopters, 22% partial adopters and 20% adopters are in less than 3 km category. In more than 6 km category, there are 60% non-adopters, 30% partial adopters and only 10% adopters. It shows no difference on adoption intensity in different distance categories.

In UAC, within adopted category, 80% farmers reside less than 3 km range from extension office and only 2% reside more than 6 km away from extension office. Among the farmers who dwell within 3 km range from extension office, 46% are adopters and only 23% are non-adopters. In more than 6 km category, 80% farmers are non-adopters and there are only 10 % adopters.

Table 4.17: Two way cross tabulation of Distance to Extension Office and Adoption Level for 3 Rice Production Practices (RPP).

Intensity of Adoption	Land preparation and planting (LPP)				Soil improvement methods (SIM)				Use of agro chemicals (UAC)			
	Distance to Extension Office (km)				Distance to Extension Office (km)				Distance to Extension Office (km)			
	≤ 3	3-6	> 6	Total	≤ 3	3-6	> 6	Total	≤ 3	3-6	> 6	Total
Not adopted	27	52	8	87	55	42	6	103	22	42	8	72
% within RPP	31	60	9	100	53	41	6	100	31	58	11	100
% within distance	28	69	80		58	56	60		23	56	80	
Partially adopted	30	8	2	40	21	22	3	46	29	23	1	53
% within RPP	75	20	5	100	46	48	7	100	55	43	2	100
% within distance	32	11	20		22	29	30		31	31	10	
Adopted	38	15	0	53	19	11	1	31	44	10	1	55
% within RPP	72	28	0	100	61	35	3	100	80	18	2	100
% within distance	40	20	0		20	15	10		46	13	10	
Total	95	75	10	180	95	75	10	180	95	75	10	180

Source: Field survey, 2004.

LPP and UAC have significance values, which are less than 0.001; hence different distance categories have different levels of adoption in LPP and UAC. But in SIM, higher significance value shows that there is no significant difference among distance categories and adoption categories (Table 4.18).

Table 4.18: Chi-Square Tests for Distance to Extension Office and Adoption Level for 3 Rice Production Practices.

	LPP	SIM	UAC
Pearson Chi-Square value	33.79	1.99	33.28
df	4	4	4
Asymp. Sig. (2-sided)	< 0.001	0.7372	< 0.001

4.3.3. Easiness to Irrigate

Since the study area is under major irrigation system, the majority of farmers (76%) have easy access to water. Only 10% and 4% are in *difficult* and *very difficult* groups respectively (Figure 4.11).

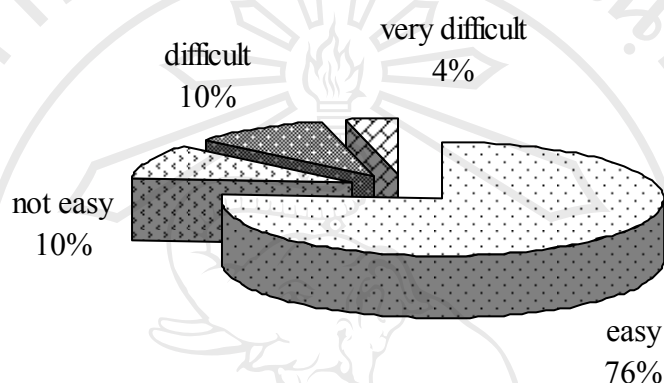

Figure 4.11: Percentage distribution of easiness to irrigate.
Source: Field survey, 2004.

In LPP, within the farmers who have severe difficulties to irrigate, 86% are non-adopters, 14% are partial adopters and there are no adopters in that group. But in the *difficult* group, there are 39% adopters and 61% non-adopters (Table 4.19). Within non-adopted category, only 63% are *easy* group and the rest 47% have some sort of difficulty in getting water while 93% in partial adopted category have easy access to water. Within adopted category, 85% are in *easy* group and 0% in *very difficult* group.

There is no such relationship between easiness to irrigate and adoption intensity in SIM practice. But in UAC practice, in *very difficult* group there are 71% non-adopters, 14% partial adopters and 14% adopters. In *easy* group more or less equal number of adopters, partial adopters and non-adopters. In non-adopted category, only 64% are in *easy* group and the rest 36% have some sort of difficulty in getting water. But in partial adopted and adopted categories, 81% and 87% have easy access to water while 21% and 13% have difficulties in getting water respectively.

Table 4.19: Two way cross tabulation of Easiness to irrigate and Adoption Level for 3 Rice Production Practices (RPP).

Intensity of Adoption	Land Preparation and Planting (LPP)					Soil Improvement Methods (SIM)					Use of Agro Chemicals (UAC)				
	Easiness to irrigate					Easiness to irrigate					Easiness to irrigate				
	easy	not easy	difficult	very difficult	Total	easy	not easy	difficult	very difficult	Total	easy	not easy	difficult	very difficult	Total
	Not adopted	55	15	11	6	87	76	12	10	5	103	46	12	9	5
% within RPP	63	17	13	7	100	74	12	10	5	100	64	17	13	7	100
% within easiness	40	83	61	86		55	67	56	71		34	67	50	71	
Partially adopted	37	2	0	1	40	36	3	6	1	46	43	5	4	1	53
% within RPP	93	5	0	3	100	78	7	13	2	100	81	9	8	2	100
% within easiness	27	11	0	14		26	17	33	14		31	28	22	14	
Adopted	45	1	7	0	53	25	3	2	1	31	48	1	5	1	55
% within RPP	85	2	13	0	100	81	10	6	3	100	87	2	9	2	100
% within easiness	33	6	39	0		18	17	11	14		35	6	28	14	
Total	137	18	18	7	180	137	18	18	7	180	137	18	18	7	180

Source: Field survey, 2004.

Since the two-sided asymptotic significance value of the chi-square statistic is smaller than 0.05 in LPP and UAC, we can conclude that there are differences among easiness groups with respect to different adoption intensities of LPP and UAC (Table 4.20). In SIM, since the chi square value is 0.871, there is no difference among easiness groups and different adoption categories.

Table 4.20: Chi-Square Tests for Easiness to irrigate and Adoption Level for 3 Rice Production Practices.

	LPP	SIM	UAC
Pearson Chi-Square value	22.34	2.48	13.08
df	6	6	6
Asymp. Sig. (2-sided)	0.001	0.871	0.042

4.3.4. Number of Trainings attended by Household Head

Within the sample 47% household heads had participated at least one training session in rice cultivation during last two years. But 57% of household heads had not received any kind of training regarding rice cultivation (Figure 4.12).

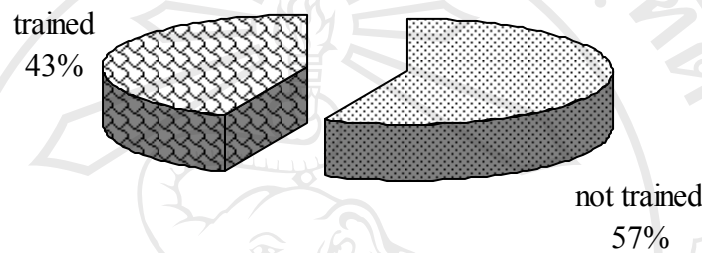

Figure 4.12: Percentage distribution of trained and not trained farmers.
Source: Field survey, 2004.

In LPP, within *trained* farmers, there are 42% adopters, 45% partial adopters and only 13% non-adopters. Within *not trained* farmers, there are only 20% adopters and 5% partial adopters while 75% are non-adopters. Within adopted category, there are 62% *trained* farmers and only 38% *not trained* farmers while in partial adopted category, 88% trained and 12% not trained farmers. In non-adopted category, 89% farmers are *not trained* and only 11% are *trained* (Table 4.21).

In SIM, within *not trained* group, 63% are non-adopters, 25% are partial adopters and 12% are adopters. Within *trained* group, 50% are non-adopters, 26% are partial adopters and 24% are adopters. Within non-adopted category, 62% are *not trained* and 38% are *trained*. Within adopted category, there are 39% *not trained* farmers and 61% *trained* farmers.

In UAC, within adopted category, 75% are *trained* farmers and only 25% are *not trained* farmers. Within non-adopted category, there are 86% *not trained* farmers and 14% *trained* farmers. There are 53% adopters, 35% partial adopters and 13%

non-adopters in *trained* group and 14% adopters, 25% partial adopters and 62% non-adopters in *not trained* group.

Table 4.21: Two way cross tabulation of Number of trainings and Adoption Level for 3 Rice Production Practices (RPP).

Intensity of Adoption	Land Preparation and Planting (LPP)			Soil Improvement Methods (SIM)			Use of Agro Chemicals (UAC)		
	Number of trainings			Number of trainings			Number of trainings		
	not trained	trained	Total	not trained	trained	Total	not trained	trained	Total
Not adopted	77	10	87	64	39	103	62	10	72
% within RPP	89	11	100	62	38	100	86	14	100
% within trainings	75	13		63	50		61	13	
Partially adopted	5	35	40	26	20	46	26	27	53
% within RPP	12	88	100	57	43	100	49	51	100
% within trainings	5	45		25	26		25	35	
Adopted	20	33	53	12	19	31	14	41	55
% within RPP	38	62	100	39	61	100	25	75	100
% within trainings	20	42		12	24		14	53	
Total	102	78	180	102	78	180	102	78	180

Source: Field survey, 2004.

The two-sided asymptotic significance value of the chi-square statistic is smaller than 0.05 in LPP and UAC, we can conclude that there are differences between *trained* and *not trained* groups with respect to different adoption intensities of LPP and UAC (Table 22). In SIM, since the chi square value is 0.069, there is no difference between *trained* and *not trained* groups with respect to different adoption intensities.

Table 4.22: Chi-Square Tests for Number of trainings and Adoption Level for 3 Rice Production Practices.

	LPP	SIM	UAC
Pearson Chi-Square value	75.43	5.33	48.49
df	2	2	2
Asymp. Sig. (2-sided)	< 0.001	0.069	< 0.001

4.3.5. Number of Field Demonstrations attended by Household Head

Thirty three (18%) farmers have not attended any demonstration within last two years while 88% farmers have attended at least one demonstration (Figure 4.13).

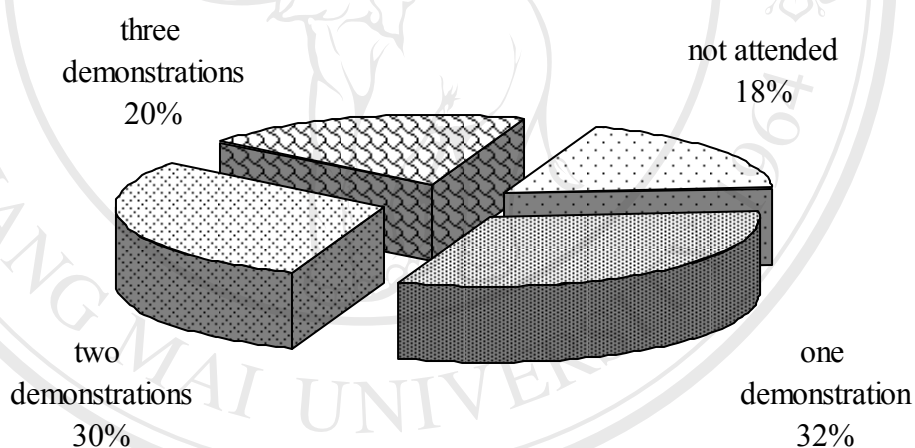

Figure 4.13: Percentage distribution of number of field demonstrations attended by household head.

Source: Field survey, 2004.

In LPP, within non-adopted category, 38% farmers have not attended any demonstration, another 38% have attended only 1 demonstration, 16% have attended 2 demonstrations and 8% have attended 3 demonstrations during last 2 years period. In adopted and partial adopted categories, all the farmers have attended at least one demonstration while 23% and 43% have attended 3 demonstrations in each category respectively (Table 4.23). All the farmers who have not attended any demonstration

are non-adopters. In non-adopted category, percentage on non-adoption is decreasing with increasing number on demonstrations.

In SIM, within adopted category, all the adopters have attended at least one demonstration and 32% have attended three demonstrations during last two years. Within the farmers who have not attended any demonstration, there are 82% non-adopters and 18% partial adopters. Within the farmers who have attended three demonstrations, there are 28% adopters, 25% partial adopters and 47% non-adopters.

Table 4.23: Two way cross tabulation of Number of field demonstrations and Adoption Level for 3 Rice Production Practices (RPP).

Intensity of Adoption	Land Preparation and Planting (LPP)					Soil Improvement Methods (SIM)					Use of Agro Chemicals (UAC)				
	Number of field demonstrations					Number of field demonstrations					Number of field demonstrations				
	0	1	2	3	Total	0	1	2	3	Total	0	1	2	3	Total
Not adopted	33	33	14	7	87	27	33	26	17	103	32	27	10	3	72
% within RPP	38	38	16	8	100	26	32	25	17	100	44	38	14	4	100
% within demonstrations	100	58	26	19		82	58	48	47		97	47	19	8	
Partially adopted	0	7	16	17	40	6	13	18	9	46	1	19	16	17	53
% within RPP	0	18	40	43	100	13	28	39	20	100	2	36	30	32	100
% within demonstrations	0	12	30	47		18	23	33	25		3	33	30	47	
Adopted	0	17	24	12	53	0	11	10	10	31	0	11	28	16	55
% within RPP	0	32	45	23	100	0	35	32	32	100	0	20	51	29	100
% within demonstrations	0	30	44	33		0	19	19	28		0	19	52	44	
Total	33	57	54	36	180	33	57	54	36	180	33	57	54	36	180

Source: Field survey, 2004.

In UAC, within adopted category, all the adopters have attended at least one demonstration, 20% have attended one demonstration, 51% have attended two demonstrations and 29% have attended three demonstrations. Within non-adopted

category, 44% farmers have not attended any demonstration and only 3% have attended 3 demonstrations during the last two years. Within partial adopted category, only 2% have not attended demonstrations and other 98% have attended at least one demonstration.

The two sided asymptotic significance values of the chi-square statistics are smaller than 0.05 and this implies that different number of demonstrations associate with different adoption intensities are different for all three-production practices (Table 4.24).

Table 4.24: Chi-Square Tests for Number of field demonstrations and Adoption Level for 3 Rice Production Practices.

	LPP	SIM	UAC
Pearson Chi-Square value	66.49	15.26	77.52
df	6	6	6
Asymp. Sig. (2-sided)	<0.001	0.018	<0.001

4.3.6. Number of Extension Office Visits by Household Head

Forty four percent of household heads have not visited the extension office at least once within the last two seasons. On average 26%, 17% and 13% farmers had visited the extension office once, twice and three times per season (Figure 4.14).

In LPP, within non-adopted category, 83% farmers have not visited extension office at all. 7% has visited once and 10% visited twice. Within partial adopters, 50% has visited 3 times, 20% has visited twice, 25% has visited once and 5% has not visited. In adopter category, 89% farmers have visited extension office at least once. Within the farmers who have visited extension office three times, 13% adopters, 87% non adopters and 0% non adopters. Within the farmers who have visited two times, 65% are adopters, 22% non adopters and 13% non adopters. Within the farmers who

have not visited the extension office, there are 90% non-adopters, 2% partial adopters and 8% adopters (Table 4.25).

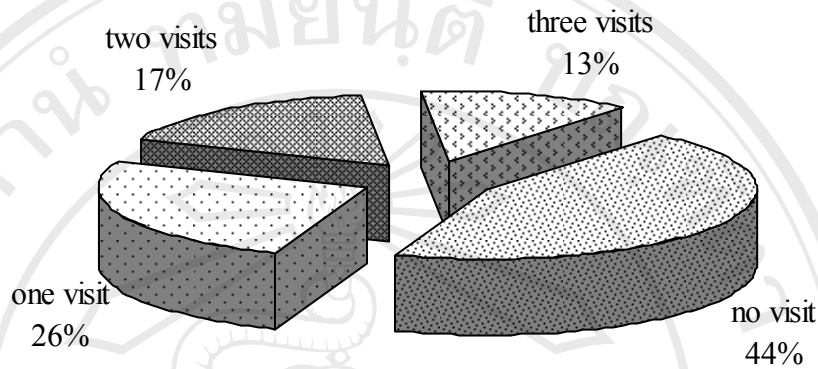

Figure 4.14: Percentage distribution of number of extension office visits by household head.

Source: Field survey, 2004.

In SIM, within non-adopter category, 59% have not visited extension office at all. Within adopter category, 97% farmers have visited the office at least once. Within the farmers who have not visited the office, there are 76% non-adopters, 23% partial adopters and 1% adopters. Within the farmers who have visited the office three times, there are 48% adopters, 26% partial adopters and 26% non-adopters. Interestingly, within the farmers who have visited the office twice, there are no adopters, 26% partial adopters and 74% non-adopters.

In UAC, within non-adopter category, 90% farmers have not visited the office and also no farmer has visited 3 times. Within the adopted category, 95% farmers have visited the office at least once. Within the farmer who has not visited the office at all, there are 81% non-adopters, 15% partial adopters and only 4% adopters. Within the farmer who has visited the office three times, there are 57% adopters, 43% partial adopters and no non-adopters.

Table 4.25: Two way cross tabulation of Number of office visits and Adoption Level for 3 Rice Production Practices (RPP).

Intensity of Adoption	Land Preparation and Planting (LPP)					Soil Improvement Methods (SIM)					Use of Agro Chemicals (UAC)				
	Number of Office visits					Number of Office visits					Number of Office visits				
	0	1	2	3	Total	0	1	2	3	Total	0	1	2	3	Total
Not adopted	72	6	9	0	87	61	13	23	6	103	65	3	4	0	72
% within RPP	83	7	10	0	100	59	13	22	6	100	90	4	6	0	100
% within office visits	90	13	29	0		76	28	74	26		81	7	13	0	
Partially adopted	2	10	8	20	40	18	14	8	6	46	12	22	9	10	53
% within RPP	5	25	20	50	100	39	30	17	13	100	23	42	17	19	100
% within office visits	2	22	26	87		23	30	26	26		15	48	29	43	
Adopted	6	30	14	3	53	1	19	0	11	31	3	21	18	13	55
% within RPP	11	57	26	6	100	3	61	0	35	100	5	38	33	24	100
% within office visits	8	65	45	13		1	41	0	48		4	46	58	57	
Total	80	46	31	23	180	80	46	31	23	180	80	46	31	23	180

Source: Field survey, 2004.

Significance values of the chi-square statistics are smaller than 0.05 for all three-rice production practices with regard to number of extension office visits by household head. Hence we can conclude that there are differences among the number of extension office visits and adoption intensities for all three rice production practices (Table 4.26).

Table 4.26: Chi-Square Tests for Number of office visits and Adoption Level for 3 Rice Production Practices.

	LPP	SIM	UAC
Pearson Chi-Square value	149.43	63.17	109.29
df	6	6	6
Asymp. Sig. (2-sided)	> 0.001	> 0.001	> 0.001

4.3.7. Number of Farm Visits by Extension Officers

Forty two percent of households had not been visited by the extension officers at least once within the last two seasons. On average 27%, 20% and 11% households had been visited by the extension officers once, twice and three times per season (Figure 4.15).

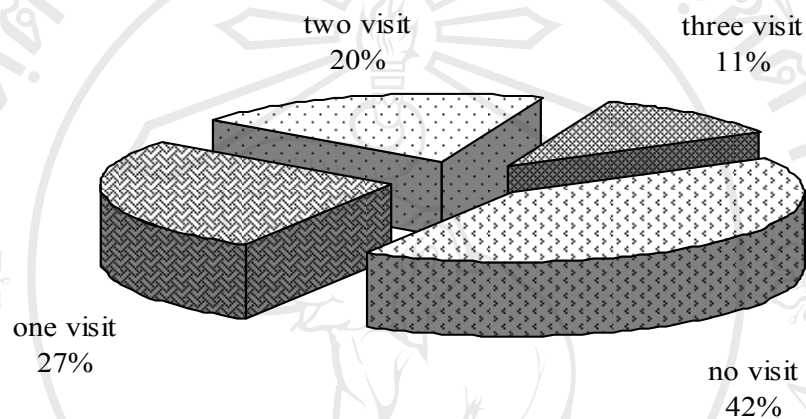

Figure 4.15: Percentage distribution of number of farm visits by extension officers. Source: Field survey, 2004.

In LPP, within non-adopted category, 75% households have not been visited by extension officers, 18% households have been visited once, 7% households have been visited 2 times. In partial adopted category, 97% households have been visited at least one time and 25% households have been visited 3 times. In adopted category, 83% households have been visited by extension officers at least once. In the households those have not been visited by extension officers, there are 87% non-adopters, 1% partial adopters and 12% adopters. In once and twice visited groups, there are 47% and 31% adopters respectively. In the households those have been visited 3 times, have no non-adopters, 50% partial adopters and 50% adopters (Table 4.27).

In SIM, within non-adopted category, 61% households have not been visited by extension officers at least once and within adopted category, 97% households have been visited at least once by extension officers. Within the households those have not

been visited at least once, there are 84% non-adopters and only 1% adopters. Within the households those have been visited at least three times, there are 65% adopters and 15% partial adopters and 20% non-adopters.

Table 4.27: Two way cross tabulation of Number of farm visits and Adoption Level for 3 Rice Production Practices (RPP).

Intensity of Adoption	Land Preparation and Planting (LPP)					Soil Improvement Methods (SIM)					Use of Agro Chemicals (UAC)				
	Number of farm visits					Number of farm visits					Number of farm visits				
	0	1	2	3	Total	0	1	2	3	Total	0	1	2	3	Total
Not adopted	65	16	6	0	87	63	20	16	4	103	59	10	3	0	72
% within RPP	75	18	7	0	100	61	19	16	4	100	82	14	4	0	100
% within farm visits	87	33	17	0		84	41	44	20		79	20	8	0	
Partially adopted	1	10	19	10	40	11	21	11	3	46	10	20	14	9	53
% within RPP	3	25	48	25	100	24	46	24	7	100	19	38	26	17	100
% within farm visits	1	20	53	50		15	43	31	15		13	41	39	45	
Adopted	9	23	11	10	53	1	8	9	13	31	6	19	19	11	55
% within RPP	17	43	21	19	100	3	26	29	42	100	11	35	35	20	100
% within farm visits	12	47	31	50		1	16	25	65		8	39	53	55	
Total	75	49	36	20	180	75	49	36	20	180	75	49	36	20	180

Source: Field survey, 2004.

In UAC, within non-adopters category, 82% households have not been visited by extension officers at least once. Within adopted category, 89% households have been visited at least once. Within the households those have not been visited by extension officers, there are 79% non-adopters, 13% partial adopters and only 8% adopters. Within the households those have been visited by extension officers more than once, there are over 50% adopters.

The two sided asymptotic significance values of the chi-square statistics are smaller than 0.05 for all three rice production practices with regard to number of farm visits by the extension officers. Hence we can conclude that there are differences among the number of farm visits and adoption intensities for all three rice production practices (Table 4.28).

Table 4.28: Chi-Square Tests for Number of farm visits and Adoption Level for 3 Rice Production Practices.

	LPP	SIM	UAC
Pearson Chi-Square value	95.03	66.81	84.56
df	6	6	6
Asymp. Sig. (2-sided)	< 0.001	< 0.001	< 0.001

4.3.8. Frequency of Listening to Agriculture Radio Programs

There are 51% *non-listeners*, 32% *irregular listeners* and only 17% *regular listeners* in the sample (Figure 4.16).

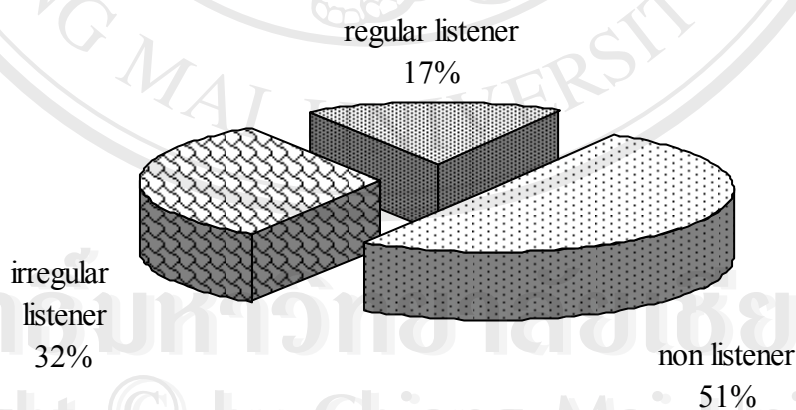

Figure 4.16: Percentage distribution of listening to agricultural radio programs.
Source: Field survey, 2004.

Within non-adopters in SIM, there are 89% *non-listeners*, 10% *irregular listeners* and only 1% *regular listeners*. Within partial adopted category, there are only 8% *non-listeners*. Within adopted category, there are only 21% *non-listeners* and 53%

irregular listeners and 26% *regular listeners*. Within *non-listeners* group, 85% are non-adopters, 3% are partial adopters and 12% are adopters. Within *regular listener* and *irregular listener* groups, there are 45% and 48% adopters respectively (Table 4.29).

There are 57% *non-listeners*, 34% *irregular listeners* and only 9% *regular listeners* within non-adopters category, in SIM. In adopter category, there are 26% *regular listeners*, 39% *irregular listeners* and 35% *non-listeners*. Within *non-listeners* group, there are 65% non-adopters and only 12% adopters. Within *irregular listener* group, there are 26% adopters, 45% partial adopters and only 29% adopters.

Table 4.29: Two way cross tabulation of Frequency of listening Agricultural Radio programs and Adoption Level for 3 Rice Production Practices (RPP).

Intensity of Adoption	Land Preparation and Planting (LPP)				Soil improvement methods (SIM)				Use of agro chemicals (UAC)			
	Frequency of listening				Frequency of listening				Frequency of listening			
	non listener	irregular listener	regular listener	Total	non listener	irregular listener	regular listener	Total	non listener	irregular listener	regular listener	Total
Not adopted	77	9	1	87	59	35	9	103	62	10	0	72
% within RPP	89	10	1	100	57	34	9	100	86	14	0	100
% within listening	85	16	3		65	60	29		68	17	0	
Partially adopted	3	21	16	40	21	11	14	46	23	26	4	53
% within RPP	8	53	40	100	46	24	30	100	43	49	8	100
% within listening	3	36	52		23	19	45		25	45	13	
Adopted	11	28	14	53	11	12	8	31	6	22	27	55
% within RPP	21	53	26	100	35	39	26	100	11	40	49	100
% within listening	12	48	45		12	21	26		7	38	87	
Total	91	58	31	180	91	58	31	180	91	58	31	180

Source: Field survey, 2004.

In UAC, within non-adopter group, there are 86% *non-listeners*, 14% *irregular listeners* and no *regular listener*. Within adopter group, there are 49%

regular listeners, 5% *irregular listeners* and no *non-listeners*. Within *non-listener* group there are 68% *non-adopters* and only 7% *adopters*. Within *regular listener* group there are 87% *adopters*, 13% *partial adopters* and no *non-adopters*.

The two sided asymptotic significance values of the chi-square statistics are smaller than 0.05 for all three-rice production practices with regard to listening categories. Therefore we can conclude that there are differences among listening categories and adoption levels for all three rice production practices (Table 4.30).

Table 4.30: Chi-Square Tests for Frequency of listening Agricultural Radio programs and Adoption Level for 3 Rice Production Practices.

	LPP	SIM	UAC
Pearson Chi-Square value	101.48	14.32	96.56
df	4	4	4
Asymp. Sig. (2-sided)	< 0.001	0.006	< 0.001

4.3.9. Frequency of Reading Agricultural Articles in Newspapers

There are 36% *non-readers*, 60% *irregular readers* and only 4% *regular readers* in the sample (Figure 4.17).

In LPP, within non-adopted category, there are 62% *non-readers*, 38% *irregular readers* and no *regular readers*. Within adopted category, there are only 4% *non-readers*, 87% *irregular readers* and 9% *regular readers*. Within *non-reader* group, there are 84% *non-adopters*, 13% *partial adopters* and 3% *adopters*. In *regular reader* group, there are 63% *adopters*, 31% *partial adopters* and there are no *non-adopters* (Table 4.31).

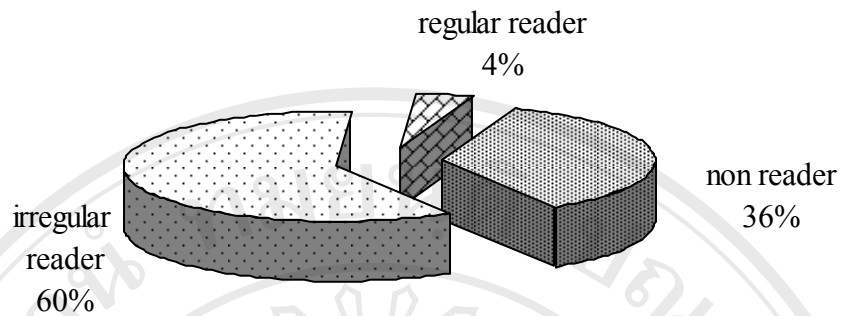

Figure 4.17: Percentage distribution of reading agricultural articles in newspapers.
Source: Field survey, 2004.

There are 40% *non-readers*, 58% *irregular readers* and 2% *regular readers* within non-adopted category, in SIM. Within adopted category, there are only 19% *non-readers*, 77% *irregular readers* and 3% *regular readers*. Within *non-reader* group, there are 64% non-adopters, 27% partial adopters and 9% adopters. In *regular reader* group, there are 13% adopters, 63% partial adopters and there are 25% non-adopters.

In UAC, within non-adopted category, there are 65% *non-readers*, 35% *irregular readers* and no *regular readers*. Within adopted category, there are no *non-readers*, 89% *irregular readers* and 11% *regular readers*. Within *non-reader* group, there are 73% non-adopters, 27% partial adopters and 0% adopters. In *regular reader* group, there are 75% adopters, 25% partial adopters and there are no non-adopters.

The two sided asymptotic significance values of the chi-square statistics are smaller than 0.05 for all three-rice production practices with regard to reading categories. Therefore we can conclude that there is relationship among frequencies of reading newspaper agriculture articles by household heads and adoption levels for all three-rice production practices (Table 4.32).

Table 4.31: Two way cross tabulation of Frequency of reading Agricultural Articles and Adoption Level for 3 Rice Production Practices (RPP).

Intensity of Adoption	Land Preparation and Planting (LPP)							Soil improvement methods (SIM)				Use of agro chemicals (UAC)				
	Frequency of reading							Frequency of reading				Frequency of reading				
	non reader	irregular reader	regular reader	regular reader	regular reader	regular reader	Total	non reader	irregular reader	regular reader	regular reader	Total	non reader	irregular reader	regular reader	Total
Not adopted	54	33	0	87	41	60	2	103	47	25	0	72				
% within practice	62	38	0	100	40	58	2	100	65	35	0	100				
% within reading	84	31	0		64	56	25		73	23	0					
Partially adopted	8	29	3	40	17	24	5	46	17	34	2	53				
% within practice	20	73	8	100	37	52	11	100	32	64	4	100				
% within reading	13	27	37		27	22	63		27	31	25					
Adopted	2	46	5	53	6	24	1	31	0	49	6	55				
% within practice	4	87	9	100	19	77	3	100	0	89	11	100				
% within reading	3	43	63		9	22	13		0	45	75					
Total	64	108	8	180	64	108	8	180	64	108	8	180				

Source: Field survey, 2004.

Table 4.32: Chi-Square Tests for Frequency of reading Agricultural Articles and Adoption Level for 3 Rice Production Practices.

	LPP	SIM	UAC
Pearson Chi-Square value	57.10	10.75	61.63
df	4	4	4
Asymp. Sig. (2-sided)	< 0.001	0.029	< 0.001

4.3.10. Frequency of Viewing Agricultural TV Programs

There are 59% *non-viewers*, 34% *irregular viewer* and only 7% *regular viewers* in the sample (Figure 4.18).

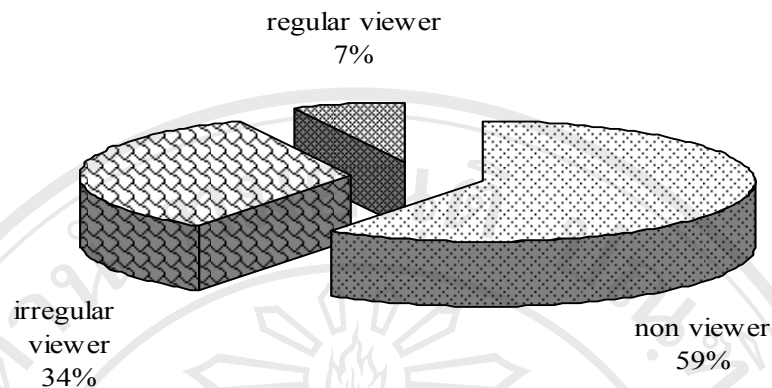

Figure 4.18: Percentage distribution of viewing agricultural TV programs.
Source: Field survey, 2004.

In LPP, within non-adopted category, there are 89% *non-viewer*, 5% *irregular viewers* and 7% *regular viewers*. Within adopted category, there are only 28% *non-viewers*, 60% *irregular viewers* and 11% *regular readers*. Within partial adopter category there are 63% *irregular viewers*. Within *non-viewer* group, there are 72% non-adopters, 14% partial adopters and 14% adopters. In *regular viewer* group, there are 50% adopters, 0% partial adopters and 50% non-adopters (Table 4.33).

There are 73% *non-viewers*, 22% *irregular viewers* and 5% *regular viewers* within non-adopted category, in SIM. Within adopted category, there are only 10% *non-viewers*, 84% *irregular viewers* and 6% *regular viewers*. Within *non-viewer* group, there are 70% non-adopters, 27% partial adopters and 3% adopters. In *irregular viewer* group there are 43% adopters, 29% partial adopters and 38% non-adopters. In *regular viewer* group, there are 17% adopters, 42% partial adopters and 42% non-adopters.

In UAC, within non-adopted category, there are 89% *non-viewers*, 7% *irregular viewers* and 4% *regular viewers*. Within adopted category, there are 36% *non-viewers*, 56% *irregular viewers* and 7% *regular viewers*. Within *non-viewer* group, there are 60% non-adopters, 21% partial adopters and 19% adopters. In

regular viewer group, there are 33% adopters, 42% partial adopters and there are 25% non-adopters.

Table 4.33: Two way cross tabulation of Frequency of viewing Agricultural TV Programs and Adoption Level for 3 Rice Production Practices (RPP).

Intensity of Adoption	Land Preparation and Planting (LPP)				Soil improvement methods (SIM)				Use of agro chemicals (UAC)			
	Frequency of viewing				Frequency of viewing				Frequency of viewing			
	non viewer	irregular viewer	regular viewer	Total	non viewer	irregular viewer	regular viewer	Total	non viewer	irregular viewer	regular viewer	Total
Not adopted	77	4	6	87	75	23	5	103	64	5	3	72
% within RPP	89	5	7	100	73	22	5	100	89	7	4	100
% within viewing	72	7	50		70	38	41		60	8	25	
Partially adopted	15	25	0	40	29	12	5	46	23	25	5	53
% within RPP	38	63	0	100	63	26	11	100	43	47	9	100
% within viewing	14	41	0		27	20	42		21	41	42	
Adopted	15	32	6	53	3	26	2	31	20	31	4	55
% within RPP	28	60	11	100	10	84	6	100	36	56	7	100
% within viewing	14	52	50		3	43	17		19	51	33	
Total	107	61	12	180	107	61	12	180	107	61	12	180

Source: Field survey, 2004.

In UAC, within non-adopted category, there are 89% *non-viewers*, 7% *irregular viewers* and 4% *regular viewers*. Within adopted category, there are 36% *non-viewers*, 56% *irregular viewers* and 7% *regular viewers*. Within *non-viewer* group, there are 60% non-adopters, 21% partial adopters and 19% adopters. In *regular viewer* group, there are 33% adopters, 42% partial adopters and there are 25% non-adopters.

The two sided asymptotic significance values of the chi-square statistics are smaller than 0.05 for all three-rice production practices with regard to viewing

categories. Therefore we can conclude that there are differences among viewing categories and adoption intensities for all three rice production practices (Table 4.34).

Table 4.34: Chi-Square Tests for Frequency of viewing Agricultural TV Programs and Adoption Level for 3 Rice Production Practices.

	LPP	SIM	UAC
Pearson Chi-Square value	71.30	45.58	45.42
df	4	4	4
Asymp. Sig. (2-sided)	< 0.001	< 0.001	< 0.001